

BRALO je nadnárodní společnost věnující se výrobě a distribuci trhacích nýtů, pevnostních nýtů, nýtovacích matic a nýtovacího nářadí.

**Naším cílem je předvídat potřeby zákazníků.
Používáme nejmodernější technologie a systémy.
Výrobní procesy jsou zárukou vysoké kvality.**



GLOBAL EXPERTISE IN FASTENING SOLUTIONS

VÝROBNÍ ZÁVODY

BRALO, S.A.

Milanos, 12. Pol.Ind. La Estación
28320 Pinto (Madrid), SPAIN
Tel.: +34 91 692 82 85
Fax: +34 91 692 10 07
E-mail: bralo@bralo.com

POBOČKY

BRALO CZ s.r.o.

Řípská 11b
627 00 Brno, CZECH REPUBLIC
Tel.: +420 545 428 611
Fax: +420 545 428 610
E-mail: bralo@bralo.cz

BRALO ITALIA S.R.L.

Via Carlo Doppieri 15
28100 Novara, ITALY
Tel.: +39 0321 622601
Fax: +39 0321 621798
E-mail: info@bralo.it

BRALO NINGBO CHINA

China Ningbo European Industrial Park
1st Bin Hai Rd. Hangzhouway Bay New Zone
Cixi City, Zhejiang, CHINA
Tel.: +86 57463077693
E-mail: bralo.cn@bralo.com

BRALO FRANCE, S.A.S

Zac Chesnes la Noirée Rue de Provence
38070 Saint Quentin Fallavier, FRANCE
Tel.: +33 4 74 946294
Fax: +33 4 74 946292
E-mail: bralo.fr@bralo.com

BRALO Baglanti Elemanlari San.ve Sti.

Tuzla Mermerciler Organize Sanayi Bölgesi 7
Sokak No: 3 Tuzla 34953 - Estambul TURKEY
Tel.: +90 216 5932710
Fax: +90 216 5932715
E-mail: bralo.tr@bralo.com

BRALO MEXICO, S.A. De C.V.

Eje 7 Norte No. 110
Parque Industrial Toluca
2000 Toluca, Edo de México
C.P. 50200 MEXICO
Tel.: +52 722 2497217
E-mail: bralo.mx@bralo.com

BRALO PORTUGUESA, Lda.

Pq. Ind. Sintra/Estoril VII – Pav.A3
Rua Tapada Nova, 9 Capa Rota – Linhó
2710-297 Sintra, PORTUGAL
Tel.: +351 21 9245270
Fax: +351 21 9245279
E-mail: bralo.pt@bralo.com

BRALO DEUTSCHLAND GmbH

Mergelfeld 24
D-31275 Lehrte OT Ahlten, GERMANY
Tel.: +49 5132 504601
Fax: +49 5132 504723
E-mail: bralo.de@bralo.com

BRALO U.K. LTD

Leabrook Road, Wednesbury,
West Midlands WS10 7NB
UNITED KINGDOM
Tel.: +44 121 567 3230
Fax: +44 121 505 1378
E-mail: bralouk@bralo.co.uk

DISTRIBUTOŘI

Rakousko
USA

Uruguay
Argentina
Čile
Rusko

Odvětví

BRALO dodává své výrobky širokému spektru zákazníků z rozličných odvětví průmyslu.

Naše výrobky jsou používány od drobných oprav a údržby až po aplikace na automatických výrobních linkách.



AUTOMATICKÁ VÝROBA

Ve všech našich výrobních závodech je zaveden systém kontroly kvality založený na přísné kontrole materiálů, výrobků a strojního zařízení.

Využíváme nejmodernější systémy počítačově řízené kontroly během celého výrobního procesu, které umožňují automatický provoz ve všech našich závodech.

CERTIFIKÁTY KVALITY



Nepřetržitá práce na vývoji a zlepšování produktů a služeb BRALO nás dovedla k zavedení systému kvality založenému na udržování požadovaných standardů. V současné době jsme držiteli těchto certifikátů:

ISO 9001:2008 potvrzuje, že firma plní požadavky zákazníků či jiných osob a splňuje zákonné či regulační nároky spojené s nabízenými produkty.

ISO TS 16949:2009 certifikuje zavedený systém kvality, který splňuje požadavky na dizajn, výrobu a servis pro výrobky určené do automobilového průmyslu.

Obsah

	Strana		Strana
Výrobky BRALO	4	HLINÍK VROUBKOVANÉ	28
Lakování a jeho možnosti	5	HLINÍK DO MĚKKÝCH MATERIÁLŮ	29
Trhací nýty	6		
Technické údaje	7		
Typy trhacích nýtů	8		
HLINÍKOVÉ NÝTY		HLINÍK SLUPKOVÉ	30
HLINÍK/OCEL STANDARDNÍ	11	Plochá hlava	31
Plochá hlava	12	Velká hlava	32
Trubkové	15		
Zapuštěná hlava	16	HLINÍK ROZPĚRNÉ	33
Velká hlava	17	Plochá hlava	34
		Velká hlava	35
		S-Trebol	35
HLINÍK/NEREZ			
Plochá hlava	19	HLINÍK TĚSNÍCÍ	36
Velká hlava	20	Plochá hlava	37
		Zapuštěná hlava	38
		Velká hlava	38
HLINÍK/HLINÍK			
Plochá hlava	22	HLINÍK/NEREZ TĚSNÍCÍ	39
Velká hlava	22	HLINÍK/NEREZ TĚSNÍCÍ	39
HLINÍK/OCEL VÍCESVĚRNÉ	23	HLINÍK/OCEL PROFILOVANÉ	40
Plochá hlava	24		
Zapuštěná hlava	25	HLINÍK/NEREZ DO BETONU	41
Velká hlava	25		
		OCELOVÉ TRHACÍ NÝTY	
HLINÍK/NEREZ VÍCESVĚRNÉ		OCEL STANDARDNÍ	42
Plochá hlava	26	Plochá hlava	43
Zapuštěná hlava	27	Zapuštěná hlava	44
Velká hlava	27	Velká hlava	45
		OCEL VÍCESVĚRNÉ	46
		OCEL SLUPKOVÉ	46
		OCEL HARDVEX	47
		OCEL TĚSNÍCÍ	48
		OCEL GRIPMATE	48



Obsah

	Strana		Strana
NEREZOVÉ TRHACÍ NÝTY		STŘIŽNÉ KOLIKY	
NEREZ A2	49	UNILOCK	63
Plochá hlava	50	BRALOCK	63
Zapuštěná hlava	51		
Velká hlava	51	SPECIÁLNÍ DÍLY	
		MOSAZNÉ UZEMŇOVACÍ	64
NEREZ A4	52	BODOVACÍ HŘEBY	64
Plochá hlava			
		DOPLŇKY	
NEREZ TĚSNÍCÍ	53	PLASTOVÉ KRYTKY	65
		PODLOŽKY	66
MĚDĚNÉ TRHACÍ NÝTY		SPEED RIVETS	67
MĚĎ/OCEL	54	SPEED RIVETS BSR	68
MĚĎ/BRONZ	54	SPEED RIVETS BSV	70
MĚĎ/OCEL TĚSNÍCÍ	55		
MĚĎ/NEREZ TĚSNÍCÍ	55	NÝTOVACÍ MATICE	
		Nýtovací matice	72
PEVNOSTNÍ NÝTY	56	Typy nýtovacích matic	73
HLINÍK PEVNOSTNÍ	57		
Plochá hlava		OCELOVÉ NÝTOVACÍ MATICE	74
Zapuštěná hlava		NEREZOVÉ NÝTOVACÍ MATICE	85
OCEL PEVNOSTNÍ	58	HLINÍKOVÉ NÝTOVACÍ MATICE	91
Plochá hlava		NÝTOVACÍ ŠROUBY	92
Zapuštěná hlava			
NEREZ PEVNOSTNÍ	59		
Plochá hlava		NÝTOVACÍ NÁŘADÍ	93
Zapuštěná hlava		Ruční nýtovací kleště na nýty	94
		Pneumatické nářadí pro	
HLINÍK HARDLOCK	60	zásobníkové nýty Speed Rivets	98
OCEL HARDLOCK	60	Pneumatické kleště na nýty	99
NEREZ HARDLOCK	61	Akumulátorové kleště na nýty	102
		Ruční nýtovací kleště na matice	104
OCEL HARDGRIP	62	Pneumatické nýtovací kleště	
NEREZ HARDGRIP	62	na matice	106



Produkty BRALO

BRALO se zabývá výrobou a vývojem svých produktů již přes 30 let. Výsledkem je v současnosti ohromné množství variací trhacích nýtů, nýtovacích matic a nářadí pro jejich aplikace, vše v nejvyšší kvalitě splňující nejnáročnější požadavky našich zákazníků.

BRALO NÝTY A STŘIŽNÉ KOLÍKY

Nabídka BRALO zahrnuje více jak 3.000 položek, pro uspokojení nejnáročnějších očekávání našich zákazníků, od základních typů trhacích nýtů přes speciální typy nýtů pro různé atypické aplikace, až po nýty pevnostní a střížné kolíky.

Dostupné jsou v ocelovém, nerezovém, hliníkovém a měděném provedení s možností různých povrchových úprav. BRALO nýty jsou všeobecně známy svým vysokým standardem. Neustálé využívání inovativních technologií pomohlo vytvořit nejucelenější řadu nýtů na trhu. Naši zákazníci mohou těžit z naší široké řady materiálů, jejich úprav a ošetření, od lakování až po design.



NÝTOVACÍ MATICE

Navrženy k dosažení nejvyšší kvality a vyrobeny k odolnosti vůči nejnáročnější zátěži okolního prostředí.

Bralo vyrábí širokou řadu nýtovacích matic. Nabízíme je s plochou, redukovanou, nebo zapuštěnou hlavou, v hladkém, vroubkovaném a šestihranném provedení. Výběr vhodného typu záleží na dané aplikaci.

Naše nýtovací matice mohou být dle typu použity pro širokou škálu materiálů, včetně měkkých, křehkých, tenkých a plastových materiálů.

NÁŘADÍ PRO APLIKACI

AKUMULÁTOROVÉ NÝTOVACÍ NÁŘADÍ

Je přenosné, rychlé a vybavené nejlepší technologií. Akumulátorové nýtovací pistole BRALO jsou kapacitně použitelné jak pro standardní nýty, tak pro nýty pevnostní.

Naše BET řada, to jsou lehké akumulátorové pistole, navrženy pro ty nejnáročnější aplikace.

BET-1 a BET-2 disponují Li-Ion bateriemi s dlouhou výdrží bez paměťového efektu.

RUČNÍ NÝTOVACÍ NÁŘADÍ

Díky neustálé snaze nabízet nejvyšší kvalitu a politice průběžného zlepšování, je ruční nýtovací nářadí BRALO uznávané a oblíbené pro svou ergonomiku, lehkost a odolnost.



PNEUMATICKO-HYDRAULICKÉ NÁŘADÍ

Navrženo pro zvýšení efektivity výrobních linek.

BM a TR řady jsou vysoce výkonné nýtovací nářadí, schopné aplikace široké řady trhacích nýtů a nýtovacích matic. Jedná se o profesionální, ergonomické nářadí s vysokou efektivitou při aplikaci.

LAKOVÁNÍ A JEHO MOŽNOSTI

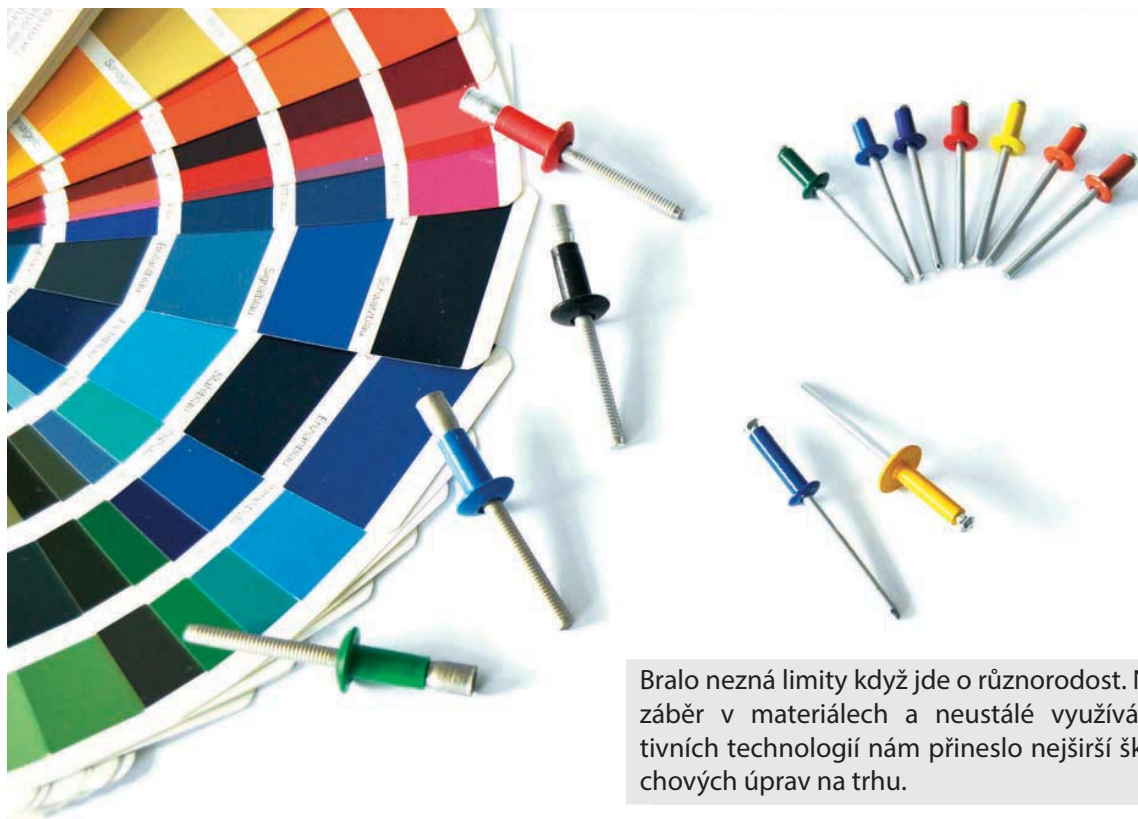

Bralo nezná limity když jde o různorodost. Náš široký záběr v materiálech a neustálé využívání inovativních technologií nám přineslo nejširší škálu povrchových úprav na trhu.

EPOXY LAKOVÁNÍ

Standardní nýty BRALO jsou dostupné v nekonečném barevném provedení, lakované tekutou epoxi barvou. Od černé po bílou, máme záběr přes 100 RAL odstínů a nabízíme rovněž speciální lakování na základě poptávky.

Abychom vyhověli přáním zákazníků, umíme nabídnout i specifické odstíny dle jednotlivých aplikací.

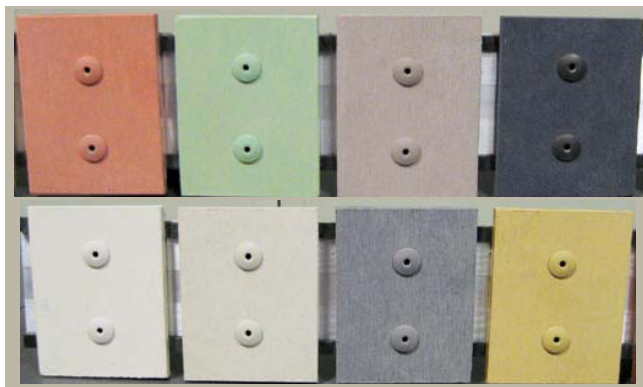

Barvy/RAL

Bronzová anodizovaná	Žlutá 1021	Modrá 5007	Modrá 5017	Šedá 7038	Šedá 7030	Šedá 7023	Hnědá 8024	Červená 3009	Zelená 6009
Hnědá anodizovaná	Žlutá 1104	Modrá 5001	Modrá 5018	Šedá 9006	Šedá 7040	Šedá 7043	Hnědá 8004	Červená 3020	Zelená 6024
Černá anodizovaná	Žlutá 1028	Modrá 5012	Modrá 5020	Šedá 7022	Šedá 7011	Šedá 7042	Hnědá 8017	Červená 3027	Zelená 6013
Zlatá anodizovaná	Žlutá 1006	Modrá 5021	Krémová 1014	Šedá 9002	Šedá 7005	Šedá 7046	Hnědá 8003	Červená 3030	Zelená 6008
Stříbrná anodizovaná	Žlutá 1003	Modrá 5009	Krémová 1011	Šedá 7024	Šedá 7015	Šedá 7048	Hnědá 8028	Červená 3016	Zelená 6011
Měděná anodizovaná	Žlutá 1004	Modrá 5003	Krémová 1015	Šedá 7035	Šedá 7004	Šedá 7008	Hnědá 8025	Červená 3002	Zelená 6019
Bílá	Žlutá 1018	Modrá 5013	Krémová 1013	Šedá 7037	Šedá 7021	Šedá 7001	Hnědá 8007	Červená 8012	Zelená 6020
Bílá 9010	Žlutá 1023	Modrá 5008	Krémová 1035	Šedá 9018	Šedá 7047	Šedá 7039	Hnědá 8001	Růžová 3012	Zelená 6021
Bílá 9001	Žlutá 1017	Modrá 5005	Vínová 3005	Šedá 7032	Šedá 7033	Oranžová 2004	Hnědá 8022	Fialová 4009	Zelená 6018
Bílá 9016	Žlutá 1034	Modrá 5014	Vínová 3007	Šedá 9007	Šedá 7003	Oranžová 2000	Hnědá 8015	Zelená 6002	Zelená 6028
Bílá 9003	Žlutá 1032	Modrá 5022	Červená 3011	Šedá 7016	Šedá 7009	Oranžová 2001	Hnědá 8023	Zelená 6003	Zelená 6032
Černá 9005	Modrá 5010	Modrá 5002	Krémová 1001	Šedá 7000	Šedá 7012	Hnědá 8014	Hnědá 8016	Zelená 6005	Zelená 6027
Černá 9011	Modrá 5011	Modrá 5000	Krémová 1002	Šedá 7031	Šedá 7013	Hnědá 8019	Červená 3000	Zelená 6007	Zelená 6029

TRHACÍ NÝTY

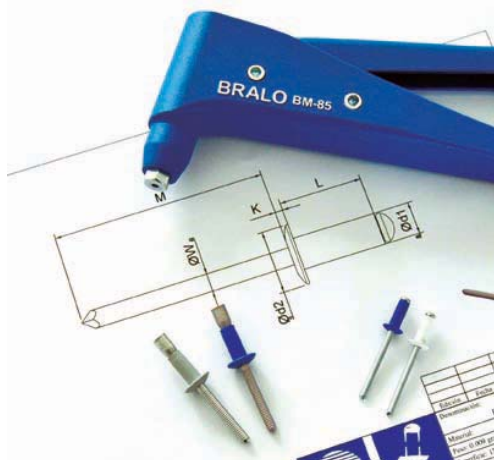

VÝHODY

- Široká škála nýtů pro různé aplikace.
- Nýty se širokým svěrným rozsahem (MULTI-GRIP).
- Trn pevně svěrný v nýtu pro vyšší pevnost a odolnost spoje (PEVNOSTNÍ NÝTY)
- Možnost speciálních designů.
- Balení dle potřeb zákazníků.
- Různé povrchové úpravy a lakování.

MATERIÁLY

Hliník Mg (EN AW 6101)

Čistý kov, nebo lakovaný.

Aplikace do měkkých materiálů s menší odolností.

Hliník Mg 2,5 (EN AW5052)

Čistý kov, nebo lakovaný. Aplikace, kde už je požadavek na pevnosti tahu a stříhu s dobrou odolností.

Hliník Mg 3 (EN AW 5754)

Čistý kov, nebo lakovaný. Použitý u standardních nýtů s velice dobrou pevností na tahu a stříhu s dobrou odolností.

Hliník Mg 3,5 (EN AW 5154)

Čistý kov, nebo lakovaný. Aplikace do měkkých materiálů. Použitý u rozpěrných nýtů TREBOL. Vysoká odolnost vůči korozi.

Hliník Mg 5,0 (EN AW 5019)

Čistý kov, nebo lakovaný. Použitý u těsnících nýtů, v aplikacích, kde je požadavek na pevnosti tahu a stříhu s vysokou odolností.

Ocel A1K, A2K, A3K (3μ, 5μ, 8μ)

Běžný materiál.

Aplikace s dobrou odolností.

Nerezová ocel (304, 316)

Odolnost vůči korozi.

Aplikace s nepříznivým vlivem prostředí.

Měď

Teplotně a elektricky vodivá.

Aplikace do měkkých materiálů.

ROZSÁHLÁ ŘADA NÝTŮ

Abychom vyšli vstříc různorodým požadavkům zákazníků na design, funkčnost, kvalitu a úsporu nákladů, nabízí BRALO přes 4.500 položek.

MATERIÁL NEJVYŠŠÍ KVALITY

BRALO testuje veškeré materiály, aby odpovídaly nejvyšším požadavkům na kvalitu, bezpečnost, pevnostní vlastnosti a trvanlivost.

DESIGN NA PŘÁNÍ

Ve spolupráci se zákazníkem nabízíme možnost výroby speciálních designů, abychom vyhověli všem přáním a požadavkům. Využíváme neustálých inovací, pro průběžné navyšování možností nabídky speciálních dílů uzpůsobených pro jednotlivé aplikace.

TYPY HLAV NÝTŮ

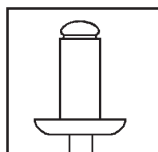

PLOCHÁ HLAVA

Jedná se o nejvšestrannější typ hlavy. Poskytuje dostatečnou styčnou plochou k svěrní všech typů materiálů, mimo extrémně jemných a křehkých.

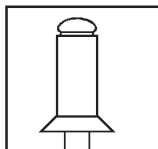

ZAPUŠTĚNÁ HLAVA

Tento typ hlavy je možné zanýtovat do silnějších materiálů. Slouží k vytvoření rovné plochy zapuštěním do aplikace.

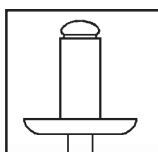

VELKÁ HLAVA

Poskytuje dvojnásobnou styčnou plochu ve srovnání s plochou hlavou a zároveň nabízí výbornou odolnost. Je vytvořena pro aplikace se spojením měkkého či křehkého materiálu, kde předejdou jeho rozlomení rozložením síly na větší plochu.



Technické údaje

S naší rychlou instalací se snižuje cena operace a zvyšuje se produktivita, Bralo má vždy řešení.

1. Vložte nýt do násadky kleští a zasuňte do otvoru v aplikaci.
2. Náradí vtahuje trn dovnitř, čímž dochází k roztažení nýtu. Po roztažení se trn utrhne.
3. Materiál je pevně spojen nýtem. Trn je z čelistí náradí uvolněn do sběrače trnů.

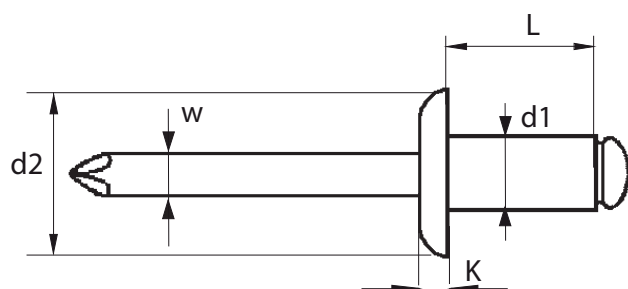
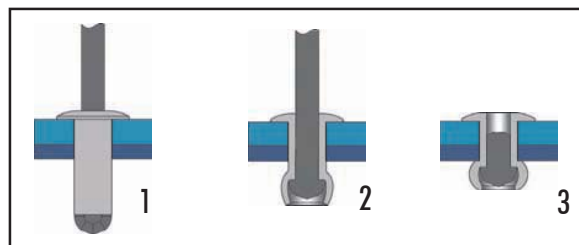

d1	Průměr těla
d2	Průměr hlavy
L	Délka těla
W	Průměr trnu
K	Výška hlavy

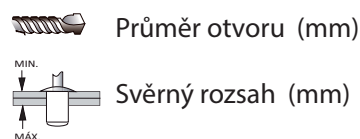

PEVNOSTI

Pevnost střihu (N)

Jedná se o limitní sílu, která může působit na nýt při působení dvou protichůdných sil kolmo k ose nýtu v aplikaci.

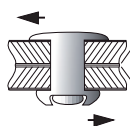

Pevnost tahu (N)

Jedná se o limitní sílu, která může působit na nýt při působení dvou protichůdných sil k rovnoběžné ose nýtu.

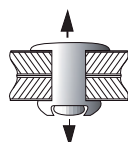

NÝTOVACÍ PROCES

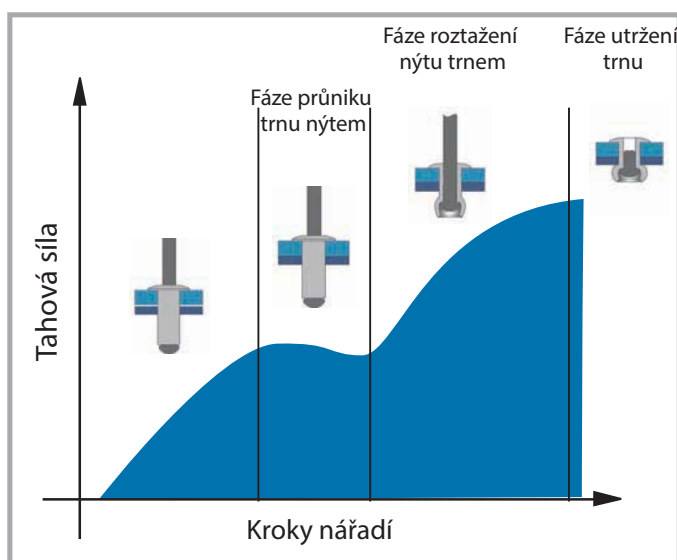

Typy trhacích nýtů

Trhací nýty: jsou druh spojovacího materiálu navržený ke spojení dvou materiálů, ať už stejných, či různých, obzvláště vhodné pro aplikace s přístupem pouze z jedné strany.

Nýty BRALO přináší bezpečné a kvalitní řešení mnoha problémů při spojování. Byly navrženy k dosažení nejvyšší kvality a vyrobeny k odolnosti vůči nepříznivým vlivům okolního prostředí.



STANDARDNÍ NÝT

Široká řada svěrných rozsahů.
Vhodné tam, kde není potřeba vysoká síla sevření.
Mnoho materiálových variací.
Rychlé, jednoduché a kvalitní spojení.

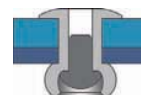

VÍCESVĚRNÝ NÝT MULTIGRIP

Široký svěrný rozsah.
Úhledné z obou stran aplikace.
Perfektně vyplní otvor a toleruje nepřesnosti v předvrtání.
Obzvláště vhodný pro aplikace s výskytem plastů a tenkých kovových materiálů.

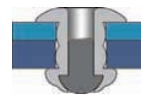

VÍCESVĚRNÝ NÝT HARDVEX

Široký svěrný rozsah.
Vysoká pevnost na tahu a střihu.
Odolnost vůči vibracím.
Obzvláště vhodný pro aplikace s výskytem tenkých a měkkých materiálů.

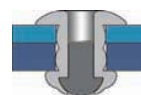

ROZPĚRNÝ NÝT TREBOL

Široký svěrný rozsah.
Vysoká odolnost vůči korozi.
Trn uzavřen v nýtu (po zanýtování nevypadne).
Vytvořen ke spojování pevných materiálů k měkkým, nebo k materiálům s menší odolností.



SLUPKOVÝ NÝT

Vytváří široce rozevřený tvar z druhé strany aplikace (banánová slupka).
Ideální pro použití v aplikacích s měkkým, nebo málo odolným materiálem.
Možno použít pro nadrozměrné otvory.
Rozkládá sílu sevření do široké oblasti (nedeforuje materiál v aplikaci).

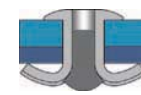

TĚSNICÍ NÝT

Vodotěsné a tlakutěsné.
Trn je uzavřen uvnitř nýtu (po zanýtování nevypadne).
Vhodný pro použití v elektrotechnice.

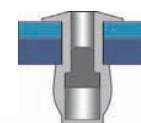

VROUBKOVANÝ NÝT

Možnost použití pro slepé díry (neprůchozí).
Vhodné pro spojení kovu se dřevem či plasty.
Poskytuje odolné spojení.

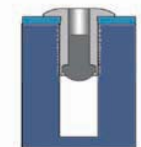

ZATLOUKAČÍ NÝT

Ideální pro spojení kovů se dřevem, cihlou či betonem.
Možnost použití pro slepé díry (neprůchozí).
Velká hlava poskytuje širokou dosedací plochu.
Odolný vůči korozi.

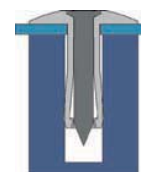



PRIFILOVANÝ NÝT

Speciálně navržený nýt s dodatečnou přidanou hodnotou v aplikaci. Pro aplikace v automobilovém průmyslu a kovovýrobě. Rychlé a jednoduché řešení snižující montážní náklady.



GRIPMATE NÝT

Velká hlava poskytuje širokou dosedací plochu. Vhodný pro použití v aplikacích s měkkým či méně odolným materiálem. Vzhledově skvělé z obou stran aplikace.

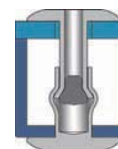

PEVNOSTNÍ NÝTY : jsou navrženy pro nejnáročnější aplikace, vyžadující výjimečnou odolnost na tahu i stříhu. Rychlé a jednoduché na instalaci. Poskytují neměnné vlastnosti v rámci své dlouhé životnosti v aplikaci.



PEVNOSTNÍ NÝT STRUCTURAL

Široký svěrný rozsah. Vysoká odolnost na tahu i stříhu. Vodotěsné a tlakutěsné. Velké rozmezí použitelnosti pro velikosti otvoru.



HARDGRIP NÝT

Ideální pro aplikace s tvrdými plasty a tenkými kovovými materiály. Vytvořeny pro nejnáročnější aplikace, vyžadující skvělou sílu sevření. Vysoká odolnost na tahu a stříhu. Zcela vyplní otvor v aplikaci.

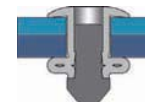

HARDLOCK NÝT

Vytvořeno pro díly vyžadující výjimečnou odolnost na tahu a stříhu. Účinný systém uzamčení hlavy díky vroubkům na trnu. Obzvláště vhodný pro práci s tenkými kovovými materiály. Vhodný pro použití v elektrotechnice.

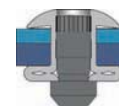

STŘIŽNÉ KOLÍKY : jsou dvoudílný spojovací materiál, který se skládá z vroubkovaného kolíku a závěrného kroužku. Výjimečně pevný spoj je získán zalisováním závěrného kroužku na kolík za použití výkonného nářadí. Střížné kolíky se používají pro vytvoření bezpečného spoje s vysokou pevností odolávajícího dlouhodobému působení sil a vibrací.



BRALOCK

Široký svěrný rozsah. Vysoká odolnost na tahu a stříhu. Odolný vůči vibracím. Použití v průmyslových aplikacích.



UNILOCK

Předepsané místo utržení. Vysoká síla sevření. Skvěle mechanicky odolný. Poskytuje čistý a jednoduchý vzhled.



Zásobníkové nýty SPEED RIVETS: synonymum rychlosti a efektivity. Jsou dodávány na papírových pásčích a používány pro magazínové nýtování při použití jednoho trnu. Použití zásobníkových nýtů SPEED RIVETS zaručuje rychlé a kvalitní spojení zvyšující produktivitu. Bez přerušení je možné zanýtovat až 60 nýtů za minutu.



SPEED RIVET BSR

Vhodné pro aplikace do kovů, plastů a slitin hliníku.
Vyšší produktivita
Radiální roztažení během aplikace.
Dobrá odolnost na stříhu



SPEED RIVET BSV

Navrženy pro aplikace s měkkým, či málo odolným materiálem
Vysoce precizní a kvalitní spoj.
Skvěle vyplňuje otvor v aplikaci.
Dobrá odolnost na stříhu.



SPECIÁLNÍ NÝTY A PŘÍSLUŠENSTVÍ:



UZEMŇOVACÍ NÝTY

Efektivní řešení uzemnění na lakovaných dílech bez poškození laku.
Optimálně vodivý, spolehlivý a odolný spoj.



BODOVACÍ HŘEBY

Ideální pro vytahování promáčklých karoserií.
Vyrobené z oceli s měděnou povrchovou úpravou.



NYLONOVÉ KRYTKY PRO NÝTY

Slouží k ochraně a vylepšení vzhledu trhacích nýtů.
Dostupné v široké barevné škále.



NYLONOVÁ ČEPIČKA PRO NÝTY

Čepičky se aplikují během nýtování.
Velice jednoduchá a rychlá aplikace.
Mohu být použity pro nýty o průměru 4,8 mm a do délky 16 mm.



OCELOVÉ PODLOŽKY PRO NÝTY

Používají se v případech, kdy zadní strana aplikace je z křehkého či měkkého materiálu (dřevo, plast, atd.), nebo v případě většího otvoru.
Užitečné pro opravy spojů po vyvrtání původních nýtů.



NEOPRÉNOVÉ PODLOŽKY PRO NÝTY

Slouží k utěsnění pod hlavou trhacího nýtu a uzavřených nýtovacích matic.
Velice jednoduché použití.

Hliníkové nýty

STANDARDNÍ NÝT

Velká škála svěrných rozsahů.

Vhodné převážně pro aplikace bez požadavku na vysokou sílu sevření.

Rychlé a jednoduché, se skvělou kvalitou spojení.



VÝBĚR VHODNÉHO NÝTU

SPOJOVANÝ MATERIÁL:

Výběr nýtu závisí na druhu spojovaných materiálů a nároků jednotlivých aplikací. Při práci s měkkým nebo křehkým materiálem (např. dřevo, plast, SPZ vozidel, apod.), bude vhodné použít nýty slupkové, rozpěrné Trebol a S-Trebol. Vícesvěrné nýty Multigrip jsou vhodné pro spojení plastů a tenkých plechů. Vroubkované nýty zase pro spojení kovů s materiály vláknitého a pórovitého charakteru jako dřevo či cihly.

SVĚRNÝ ROZSAH:

Celková tloušťka spojovaných materiálů musí být v souladu s předepsaným svěrným rozsahem zvoleného trhačického nýtu. Pevnostní nýty STRUCTURAL, vícesvěrné nýty MULTIGRIP a rozpěrné TREBOL nýty disponují širokým svěrným rozsahem a mohou být tedy použity pro více aplikací. Což snižuje potřebu nákupu mnoha rozměrů.

VELIKOST OTVORU V APLIKACI:

Vhodná velikost otvoru je uvedena v tabulce u všech položek. Dodržení předepsaných rozměrů je nutné k dosažení požadovaných vlastností.

BEZPEČNĚ UZAVŘENÉ SPOJE:

Jsou řešením pro případy možných úniků kapalin a plynů, kdy je nutné, aby nýt kompletně uzavřel otvor, jako například při použití nýtů Těsnících, Pevnostních STRUCTURAL, rozpěrných těsnících S-TREBOL. Rovněž odolávají vibracím a vylučují problém v elektrotechnice, kdy nemůže dojít k vypadnutí zbytku trnu z nýtu.

ODOLNOST VŮČI KOROZI:

Rozhodujícím faktorem při výběru nýtu, je požadovaná odolnost vůči korozi pro jednotlivou aplikaci. Pro dosažení nejvyšší odolnosti je důležité, aby byly všechny materiály ve shodě s materiály v aplikaci. Při větším nároku na odolnost volíme nerezové materiály A2 a A4. Použití ochranných povrchových úprav (anodizování, galvanizace, delta-Seal) zlepšuje odolnost pro díly více exponované náročnému prostředí.

PEVNOST NA TAHU A STŘIHU:

Obsah hořčíku u hliníkových nýtů má vliv na pevnost v tahu a stříhu.

BRALO Pevnostní STRUCTURAL nýty a střížné kolíky jsou nejlepší pro vysoce zátěžové aplikace.

BAREVNÉ PŘEDVEDENÍ:

Estetická některých aplikací vyžaduje, aby nýt barevně zapadl. Nýty BRALO jsou nabízeny v nespočetném barevném provedení, lakováním epoxy. Máme v nabídce více jak 100 standardních barev od bílé až po černou dle vzorníku RAL.

STANDARDNÍ NÝTY

Plochá hlava

HLINÍK/OCEL





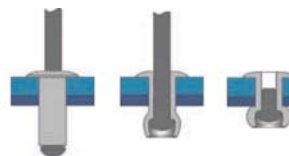
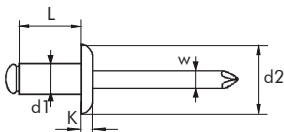

TĚLO: Hliník Al Mg 3,5

TRN: Pozinkovaná ocel A1K

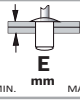

UNE - EN ISO 15977

Testováno dle EN ISO 14589

d1 Ø mm	L Nominální mm	 mm	d2 Ø mm	K mm	W Ø mm	BALENÍ		 E mm MIN. MÁX.	 (N)	 (N)	Kód zboží
						 vnitřní	 veškovní				
2,4	4	2,50	5,00	0,60	1,45	1.000	8.000	0,5 - 2,0	350	550	01010002404
	6					1.000	8.000	2,0 - 4,0			01010002406
	8					1.000	8.000	4,0 - 6,0			01010002408
	10					1.000	8.000	6,0 - 8,0			01010002410
	12					1.000	8.000	8,0 - 9,5			01010002412
3,0	4	3,10	6,00	1,00	1,80	500	4.000	0,5 - 1,5	550	850	01010003004
	5					500	4.000	0,5 - 2,5			01010003005
	6					500	4.000	1,5 - 3,5			01010003006
	7					500	4.000	1,5 - 4,5			01010003007
	8					500	4.000	3,5 - 5,0			01010003008
	9					500	4.000	4,5 - 6,0			01010003009
	10					500	4.000	5,0 - 7,0			01010003010
	12					500	4.000	7,0 - 9,0			01010003012
	14					500	4.000	9,0 - 11,0			01010003014
	16					500	4.000	11,0 - 13,0			01010003016
18					500	4.000	13,0 - 15,0			01010003018	
3,2	4	3,30	6,40	1,00	1,80	500	4.000	0,5 - 1,5	750	1100	01010003204
	5					500	4.000	0,5 - 2,5			01010003205
	6					500	4.000	1,5 - 3,5			01010003206
	8					500	4.000	3,5 - 5,0			01010003208
	10					500	4.000	5,0 - 7,0			01010003210
	12					500	4.000	7,0 - 9,0			01010003212
	15					500	4.000	9,0 - 12,0			01010003215
	18					500	4.000	12,0 - 15,0			01010003218
	20					500	4.000	15,0 - 17,0			01010003220
	4,0	5	4,10	8,00	1,40	2,20	500	4.000	0,5 - 2,5	1250	1800
6						500	4.000	1,0 - 3,0			01010004006
7						500	4.000	3,0 - 4,5			01010004007
8						500	4.000	3,0 - 5,0			01010004008
10						500	4.000	5,0 - 6,5			01010004010
12						500	3.000	6,5 - 8,5			01010004012
14						500	3.000	8,5 - 10,5			01010004014
16						500	3.000	10,5 - 12,5			01010004016
18						500	3.000	12,5 - 14,5			01010004018
20						500	3.000	14,5 - 16,5			01010004020
25						250	1.500	16,5 - 21,0			01010004025
30						250	1.500	21,0 - 26,0			01010004030
35						250	1.500	26,0 - 31,0			01010004035
40						250	1.500	31,0 - 36,0			01010004040
4,8	6	4,90	9,50	1,50	2,65	500	3.000	0,5 - 3,0	1850	2600	01010004806
	8					500	3.000	3,0 - 4,5			01010004808
	10					500	3.000	4,5 - 6,0			01010004810
	12					500	3.000	6,0 - 8,0			01010004812
	14					250	2.000	8,0 - 10,0			01010004814
	16					250	2.000	10,0 - 12,0			01010004816
	18					250	1.500	12,0 - 14,0			01010004818
	21					250	1.500	14,0 - 17,0			01010004821
	24					200	1.200	17,0 - 20,0			01010004824
	27					200	1.200	20,0 - 23,0			01010004827
	30					200	1.200	23,0 - 25,0			01010004830
	32					150	900	25,0 - 27,0			01010004832
	35					150	900	27,0 - 30,0			01010004835
	40					150	900	30,0 - 35,0			01010004840
	45					100	600	35,0 - 40,0			01010004845
	50					100	600	40,0 - 45,0			01010004850

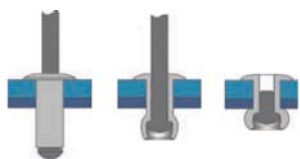





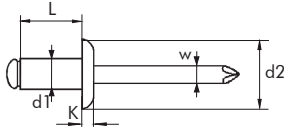

TĚLO: Hliník Al Mg 3,5

TRN: Pozinkovaná ocel A1K



UNE - EN ISO 15977

Testováno dle EN ISO 14589

d1 Ø mm	L Nominiální mm	 mm	d2 Ø mm	K mm	W Ø mm	BALENÍ		 E mm MIN. MÁX.	 (N)	 (N)	Kód zboží
						 vnitřní	 veškovní				
5,0	6	5,10	9,50	1,60	2,65	500	3.000	0,5 - 3,0	2150	3100	01010005006
	8					500	3.000	3,0 - 4,5			01010005008
	10					500	3.000	4,5 - 6,0			01010005010
	12					500	3.000	6,0 - 8,0			01010005012
	14					250	2.000	8,0 - 10,0			01010005014
	16					250	2.000	10,0 - 12,0			01010005016
	18					250	1.500	12,0 - 14,0			01010005018
	20					250	1.500	14,0 - 16,0			01010005020
	25					200	1.200	16,0 - 21,0			01010005025
	30					200	1.200	21,0 - 25,0			01010005030
	35					150	900	25,0 - 30,0			01010005035
	40					150	900	30,0 - 35,0			01010005040
	45					100	600	35,0 - 40,0			01010005045
50					100	600	40,0 - 45,0			01010005050	
6,0	8	6,10	12,0	1,80	3,20	250	1.500	2,0 - 3,0	3200	4600	01010006008
	10					250	1.500	3,0 - 5,0			01010006010
	12					250	1.500	5,0 - 7,0			01010006012
	14					250	1.500	7,0 - 9,0			01010006014
	16					250	1.500	9,0 - 11,0			01010006016
	18					200	1.200	11,0 - 13,0			01010006018
	20					200	1.200	13,0 - 15,0			01010006020
	25					200	1.200	15,0 - 20,0			01010006025
30					150	900	20,0 - 25,0			01010006030	
35					100	600	25,0 - 30,0			01010006035	
6,4	12	6,50	13,0	2,20	3,60	250	1.500	3,0 - 6,0	3400	4850	01010006412
	15					250	1.500	6,0 - 9,0			01010006415
	18					200	1.200	9,0 - 12,0			01010006418
	22					200	1.200	12,0 - 16,0			01010006422
	26					150	900	16,0 - 20,0			01010006426
	30					150	900	20,0 - 24,0			01010006430
	35					100	600	24,0 - 29,0			01010006435
50						500	29,0 - 42,0			01010006450	
7,8	15	8,00	13,5	2,20	3,60		1.000	6,0 - 9,0	5000	7500	G1010007815
	22						1.000	9,0 - 16,0			G1010007822



UNE - EN ISO 15977

d1 Ø mm	L Nominiální mm	BARVENO BÍLE	BARVENO ČERNĚ RAL 9005	OSTATNÍ BARVY	BALENÍ	
		Kód zboží	Kód zboží	Kód zboží	vnitřní	veškovní
2,4	4	01010BL2404	01010N02404	01010 2404	1.000	8.000
	6	01010BL2406	01010N02406	01010 2406	1.000	8.000
	8	01010BL2408	01010N02408	01010 2408	1.000	8.000
3,2	5	01010BL3205	01010N03205	01010 3205	500	4.000
	6	01010BL3206	01010N03206	01010 3206	500	4.000
	8	01010BL3208	01010N03208	01010 3208	500	4.000
	10	01010BL3210	01010N03210	01010 3210	500	4.000
	12	01010BL3212	01010N03212	01010 3212	500	4.000
	15	01010BL3215	01010N03215	01010 3215	500	4.000
	18	01010BL3218	01010N03218	01010 3218	500	4.000
4,0	6	01010BL4006	01010N04006	01010 4006	500	4.000
	7	01010BL4007	01010N04007	01010 4007	500	4.000
	8	01010BL4008	01010N04008	01010 4008	500	4.000
	10	01010BL4010	01010N04010	01010 4010	500	4.000
	12	01010BL4012	01010N04012	01010 4012	500	3.000
	14	01010BL4014	01010N04014	01010 4014	500	3.000
	16	01010BL4016	01010N04016	01010 4016	500	3.000
	18	01010BL4018	01010N04018	01010 4018	500	3.000
	20	01010BL4020	01010N04020	01010 4020	500	3.000
	25	01010BL4025	01010N04025	01010 4025	250	1.500
	30	01010BL4030	01010N04030	01010 4030	250	1.500
4,8	6	01010BL4806	01010N04806	01010 4806	500	3.000
	8	01010BL4808	01010N04808	01010 4808	500	3.000
	10	01010BL4810	01010N04810	01010 4810	500	3.000
	12	01010BL4812	01010N04812	01010 4812	500	3.000
	14	01010BL4814	01010N04814	01010 4814	250	2.000
	16	01010BL4816	01010N04816	01010 4816	250	2.000
	18	01010BL4818	01010N04818	01010 4818	250	1.500
	21	01010BL4821	01010N04821	01010 4821	250	1.500
	24	01010BL4824	01010N04824	01010 4824	200	1.200
	27	01010BL4827	01010N04827	01010 4827	200	1.200
	30	01010BL4830	01010N04830	01010 4830	200	1.200
	32	01010BL4832	01010N04832	01010 4832	150	1.200
	35	01010BL4835	01010N04835	01010 4835	150	900
	40	01010BL4840	01010N04840	01010 4840	150	900
	45	01010BL4845	01010N04845	01010 4845	100	600
50	01010BL4850	01010N04850	01010 4850	100	600	



DOSTUPNÉ BARVY DLE RAL VZORNÍKU

Barvy	RAL	Kód	Barvy	RAL	Kód	Barvy	RAL	Kód	Barvy	RAL	Kód	Barvy	RAL	Kód
Bronzová	AB		Modrá	5008	A8	Šedá	7038	G0	Šedá	7013	GS	Červená	3027	R3
Hnědá	AM		Modrá	5005	A9	Šedá	9006	G1	Šedá	7023	GU	Červená	3003	R4
Černá	AN		Modrá	5014	AA	Šedá	7022	G2	Šedá	7043	GV	Červená	3016	R5
Žlutá	AO		Modrá	5022	AC	Šedá	9002	G3	Šedá	7042	GZ	Červená	3002	RC
Stříbrná	AP		Modrá	5017	AD	Šedá	7024	G4	Šedá	7046	H6	Červená	8012	RP
Měděná	CU		Modrá	5011	AE	Šedá	7035	G5	Šedá	7048	H8	Růžová	3012	RO
Žlutá	1021	J0	Modrá	5020	AF	Šedá	7037	G6	Sedá	7008	HA	Oranžová	2004	NA
Žlutá	1104	J1	Modrá	5002	AG	Šedá	9018	G7	Hnědá	8014	M0	Oranžová	2000	NB
Žlutá	1028	J2	Modrá	5008	AH	Šedá	7032	G8	Hnědá	8019	M1	Oranžová	2001	NC
Žlutá	1006	J3	Modrá	5000	AJ	Šedá	9007	G9	Hnědá	8024	M2	Zelená	6002	V0
Žlutá	1003	J4	Modrá	5018	AK	Šedá	7016	GA	Hnědá	8004	M3	Zelená	6005	V1
Žlutá	1004	J5	Béžová	1014	B4	Šedá	7000	GB	Hnědá	8017	M4	Zelená	6021	V2
Žlutá	1018	J6	Béžová	1011	B5	Šedá	7031	GC	Hnědá	8003	M5	Zelená	6009	V3
Žlutá	1023	J7	Béžová	1015	BE	Šedá	7040	GD	Hnědá	8028	M6	Zelená	6024	V4
Žlutá	1017	JA	Béžová	1013	B1	Šedá	7030	GE	Hnědá	8025	M7	Zelená	6003	V5
Žlutá	1034	JP	Bílá	9001	B3	Šedá	7011	GF	Hnědá	8007	M8	Zelená	6013	V6
Žlutá	1032	JR	Bílá		BL	Šedá	7005	GG	Hnědá	8001	M9	Zelená	6008	V7
Modrá	5010	A0	Bílá	9016	BM	Šedá	7015	GH	Hnědá	8022	MA	Zelená	6011	V8
Modrá	5007	A1	Bílá	9003	B5	Šedá	7004	GI	Hnědá	8015	MC	Zelená	6019	V9
Modrá	5001	A2	Bílá	9010	BB	Šedá	7021	GJ	Hnědá	8023	MN	Zelená	6020	VC
Modrá	5012	A3	Krémová	1001	C0	Šedá	7047	GL	Černá	9005	N0	Zelená	6018	VD
Modrá	5021	A4	Krémová	1002	C1	Šedá	7033	GM	Černá	9011	N1	Zelená	6028	VP
Modrá	5009	A5	Vínově červená	3005	D0	Šedá	7003	GN	Červená	3000	R0	Zelená	6032	VS
Modrá	5003	A6	Vínově červená	3007	D1	Šedá	7009	GP	Červená	3009	R1	Zelená	6027	VL
Modrá	5013	A7	Červená	3011	D2	Sedá	7012	GR	Červená	3020	R2	Zelená	6029	VM

Názvy barev jsou orientační.
Např. Bronzový nýt 4,8x35 01010AB4835

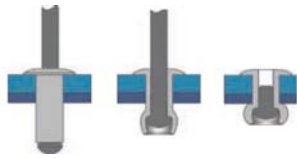





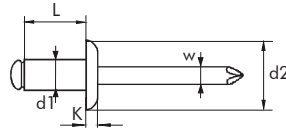

TĚLO: Hliník Al Mg 3



TRN: Pozinkovaná ocel A1K



UNE - EN ISO 15977

Testováno dle EN ISO 14589

d1 Ø mm	L Nominální mm		d2 Ø mm	K mm	W Ø mm	BALENÍ					Kód zboží
						 vnitřní	 veknovní				
5,0	55	5,10	9,30	1,50	3,73	100	600	45,0 - 50,0	2000	2750	01050005055
	60						500	50,0 - 55,0			01050005060
	65						500	55,0 - 60,0			01050005065
	70						500	60,0 - 65,0			01050005070
	75						500	65,0 - 70,0			01050005075
	80						500	70,0 - 75,0			01050005080
	90						500	75,0 - 85,0			01050005090
	100						500	85,0 - 95,0			010500050100
	110						500	95,0 - 105,0			010500050110
	120						250	105,0 - 115,0			010500050120
	130						250	115,0 - 125,0			010500050130
	140						250	125,0 - 135,0			010500050140
	150						250	135,0 - 145,0			010500050150
	160						250	145,0 - 155,0			010500050160
170						250	155,0 - 165,0			010500050170	
180						250	165,0 - 175,0			010500050180	
190						250	175,0 - 185,0			010500050190	
6,4	80	6,50	12,5	2,00	3,60		500	42,0 - 73,0	2450	3400	01050006480
	100						250	73,0 - 93,0			010500064100
	120						250	93,0 - 113,0			010500064120
	150						250	113,0 - 143,0			010500064150
	175						250	143,0 - 168,0			010500064175

d1 Ø m/m	L Nominální m/m	BARVENO BÍLE		OSTATNÍ BARVY		BALENÍ	
		Kód zboží		Kód zboží		 vnitřní	 veknovní
4,0	35	01050BL4035		01050	4035	250	1.500
	40	01050BL4040		01050	4040	250	1.500
5,0	40	01050BL5040		01050	5040	150	900
	45	01050BL5045		01050	5045	100	600
	50	01050BL5050		01050	5050	100	600
	55	01050BL5055		01050	5055	100	600
	60	01050BL5060		01050	5060		500
	65	01050BL5065		01050	5065		500
	70	01050BL5070		01050	5070		500
	75	01050BL5075		01050	5075		500
	80	01050BL5080		01050	5080		500



STANDARDNÍ NÝTY

Zapuštěná hlava 120°

HLINÍK/OCEL





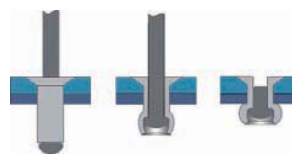
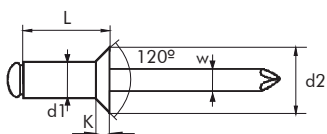

TĚLO: Hliník Al Mg 3,5

TRN: Pozinkovaná ocel A1K

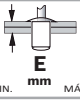

UNE - EN ISO 15978

Testováno dle EN ISO 14589

d1 Ø mm	L Nominalní mm	 mm	d2 Ø mm	K mm	W mm	BALENÍ		 E mm MIN. MÁX.	 (N)	 (N)	Kód zboží
						 vnitřní	 veknovní				
2,4	6	2,50	5,00	0,80	1,45	1.000	8.000	2,0 - 4,0	350	550	01020002406
	8					1.000	8.000	4,0 - 6,0			01020002408
	10					1.000	8.000	6,0 - 8,0			01020002410
3,0	6	3,10	6,00	1,10	1,80	500	4.000	2,0 - 3,5	550	850	01020003006
	8					500	4.000	3,5 - 5,0			01020003008
	10					500	4.000	5,0 - 7,0			01020003010
	12					500	4.000	7,0 - 9,0			01020003012
	14					500	4.000	9,0 - 11,0			01020003014
3,2	6	3,30	6,40	1,10	1,80	500	4.000	2,0 - 3,5	750	1100	01020003206
	8					500	4.000	3,5 - 5,0			01020003208
	10					500	4.000	5,0 - 7,0			01020003210
	12					500	4.000	7,0 - 9,0			01020003212
	15					500	4.000	9,0 - 12,0			01020003215
4,0	6	4,10	7,80	1,40	2,20	500	4.000	1,5 - 3,0	1250	1800	01020004006
	8					500	4.000	3,0 - 5,0			01020004008
	10					500	4.000	5,0 - 6,5			01020004010
	12					500	3.000	6,5 - 8,5			01020004012
	14					500	3.000	8,5 - 10,5			01020004014
	16					500	3.000	10,5 - 12,5			01020004016
	18					500	3.000	12,5 - 14,5			01020004018
4,8	6	4,90	9,50	1,80	2,65	500	3.000	2,0 - 3,0	1850	2600	01020004806
	8					500	3.000	3,0 - 4,5			01020004808
	10					500	3.000	4,5 - 6,0			01020004810
	12					500	3.000	6,0 - 8,0			01020004812
	14					250	2.000	8,0 - 10,0			01020004814
	16					250	2.000	10,0 - 12,0			01020004816
	18					250	1.500	12,0 - 14,0			01020004818
	21					250	1.500	14,0 - 17,0			01020004821
	24					200	1.200	17,0 - 20,0			01020004824
	27					200	1.200	20,0 - 23,0			01020004827
	30					200	1.200	23,0 - 25,0			01020004830
5,0	6	5,10	9,50	1,80	2,65	500	3.000	2,0 - 3,0	2150	3100	01020005006
	8					500	3.000	3,0 - 4,5			01020005008
	10					500	3.000	4,5 - 6,0			01020005010
	12					500	3.000	6,0 - 8,0			01020005012
	14					250	2.000	8,0 - 10,0			01020005014
	16					250	2.000	10,0 - 12,0			01020005016
	18					250	2.000	12,0 - 14,0			01020005018
	20					250	1.500	14,0 - 16,0			01020005020
	25					200	1.200	16,0 - 21,0			01020005025
	30					200	1.200	21,0 - 25,0			01020005030

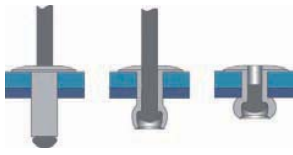



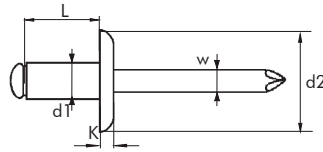

TĚLO: Hliník Al Mg 3,5

TRN: Pozinkovaná ocel A1K



Testováno dle EN ISO 14589

d1 Ø m/m	L Nominiální m/m	 m/m	d2 Ø m/m	K m/m	W Ø m/m	BALENÍ		E MIN. m/m MAX.	 (N)	 (N)	Kód zboží
						 vnitřní	 veškovní				
3,2	6	3,30	9,50	1,10	1,80	500	4.000	0,5 - 3,5	750	1100	01030003206
	8					500	4.000	3,5 - 5,0			01030003208
	10					500	4.000	5,0 - 7,0			01030003210
	12					500	4.000	7,0 - 9,0			01030003212
	16					500	3.000	9,0 - 13,0			01030003216
4,0	8	4,10	12,00	1,40	2,20	500	3.000	3,0 - 5,0	1250	1800	01040004008
	10					500	3.000	5,0 - 6,5			01040004010
	12					250	2.000	6,5 - 8,5			01040004012
	14					250	2.000	8,5 - 10,5			01040004014
	16					250	2.000	10,5 - 12,5			01040004016
	18					250	2.000	12,5 - 14,5			01040004018
	20					250	2.000	14,5 - 16,5			01040004020
4,8	10	4,90	14,00	1,80	2,65	250	1.500	4,5 - 6,0	1850	2600	01030004810
	12					250	1.500	6,0 - 8,0			01030004812
	14					250	1.500	8,0 - 10,0			01030004814
	16					250	1.500	10,0 - 12,0			01030004816
	18					200	1.200	12,0 - 14,0			01030004818
	21					200	1.200	14,0 - 17,0			01030004821
	24					150	900	17,0 - 20,0			01030004824
	27					150	900	20,0 - 23,0			01030004827
	30					150	900	23,0 - 25,0			01030004830
	35					100	600	25,0 - 30,0			01030004835
	40					100	600	30,0 - 35,0			01030004840
	45					100	600	35,0 - 40,0			01030004845
	50					100	600	40,0 - 45,0			01030004850
	4,8	10				4,90	16,00	1,80			2,65
12			250	1.500	6,0 - 8,0	01040004812					
14			200	1.200	8,0 - 10,0	01040004814					
16			200	1.200	10,0 - 12,0	01040004816					
18			200	1.200	12,0 - 14,0	01040004818					
21			150	900	14,0 - 17,0	01040004821					
24			150	900	17,0 - 20,0	01040004824					
27			150	900	20,0 - 23,0	01040004827					
30			100	600	23,0 - 25,0	01040004830					
35			100	600	25,0 - 30,0	01040004835					
4,8		25	4,90	19,00	1,80	2,65				1.000	
	30						1.000	20,0 - 25,0	G1041004830		
5,0	8	5,10	11,00	1,60	2,65	250	2.000	3,0 - 4,5	2150	3100	01031005008
	10					250	2.000	4,5 - 6,0			01031005010
	12					250	2.000	6,0 - 8,0			01031005012
	14					250	1.500	8,0 - 10,0			01031005014
	16					250	1.500	10,0 - 12,0			01031005016
	18					250	1.500	12,0 - 14,0			01031005018
	20					250	1.500	14,0 - 16,0			01031005020
	25					200	1.200	16,0 - 21,0			01031005025
	30					200	1.200	21,0 - 25,0			01031005030
	5,0	8				5,10	14,00	1,80			2,65
10			250	1.500	4,5 - 6,0	01030005010					
12			250	1.500	6,0 - 8,0	01030005012					
14			250	1.500	8,0 - 10,0	01030005014					
16			250	1.500	10,0 - 12,0	01030005016					
18			200	1.200	12,0 - 14,0	01030005018					
20			200	1.200	14,0 - 16,0	01030005020					
25			150	900	16,0 - 21,0	01030005025					
30			150	900	21,0 - 25,0	01030005030					
6,4	10	6,50	15,00				1.000				G1035006410
	12						1.000				G1035006412

STANDARDNÍ BAREVNÉ NÍTY

Zapuštěná hlava 120°

HLINÍK/OCEL

UNE - EN ISO 15978



d1 Ø m/m	L Nominiální m/m	BARVENO BÍLE	BARVENO ČERNĚ	OSTATNÍ BARVY	BALENÍ	
		Kód zboží	Kód zboží	Kód zboží	vnitřní	veškovní
3,2	6	01020BL3206	01020N03206	01020 3206	500	4.000
	8	01020BL3208	01020N03208	01020 3208	500	4.000
	10	01020BL3210	01020N03210	01020 3210	500	4.000
	12	01020BL3212	01020N03212	01020 3212	500	4.000
	15	01020BL3215	01020N03215	01020 3215	500	4.000
	18	01020BL3218	01020N03218	01020 3218	500	4.000
4,0	6	01020BL4006	01020N04006	01020 4006	500	4.000
	8	01020BL4008	01020N04008	01020 4008	500	4.000
	10	01020BL4010	01020N04010	01020 4010	500	4.000
	12	01020BL4012	01020N04012	01020 4012	500	3.000
	14	01020BL4014	01020N04014	01020 4014	500	3.000
	16	01020BL4016	01020N04016	01020 4016	500	3.000
	18	01020BL4018	01020N04018	01020 4018	500	3.000
	20	01020BL4020	01020N04020	01020 4020	500	3.000
4,8	6	01020BL4806	01020N04806	01020 4806	500	3.000
	8	01020BL4808	01020N04808	01020 4808	500	3.000
	10	01020BL4810	01020N04810	01020 4810	500	3.000
	12	01020BL4812	01020N04812	01020 4812	500	3.000
	14	01020BL4814	01020N04814	01020 4814	250	2.000
	16	01020BL4816	01020N04816	01020 4816	250	2.000
	18	01020BL4818	01020N04818	01020 4818	250	1.500
	21	01020BL4821	01020N04821	01020 4821	250	1.500
	24	01020BL4824	01020N04824	01020 4824	200	1.200
	27	01020BL4827	01020N04827	01020 4827	200	1.200
	30	01020BL4830	01020N04830	01020 4830	200	1.200
	35	01020BL4835	01020N04835	01020 4835	150	900

STANDARDNÍ BAREVNÉ NÍTY

Velká hlava

HLINÍK/OCEL



d1 Ø m/m	L Nominiální m/m	BARVENO BÍLE	BARVENO ČERNĚ	OSTATNÍ BARVY	BALENÍ	
		Kód zboží	Kód zboží	Kód zboží	vnitřní	veškovní
3,2	6	01030 BL3206	01030 N03206	01030 3206	500	4.000
	8	01030 BL3208	01030 N03208	01030 3208	500	4.000
	10	01030 BL3210	01030 N03210	01030 3210	500	4.000
	12	01030 BL3212	01030 N03212	01030 3212	500	4.000
	16	01030 BL3216	01030 N03216	01030 3216	500	4.000
4,0	8	01040 BL4008	01040 N04008	01040 4008	500	3.000
	10	01040 BL4010	01040 N04010	01040 4010	500	3.000
	12	01040 BL4012	01040 N04012	01040 4012	250	2.000
	14	01040 BL4014	01040 N04014	01040 4014	250	2.000
	16	01040 BL4016	01040 N04016	01040 4016	250	2.000
	18	01040 BL4018	01040 N04018	01040 4018	250	2.000
	20	01040 BL4020	01040 N04020	01040 4020	250	2.000
4,8	10	01030 BL4810	01030 N04810	01030 4810	250	1.500
	12	01030 BL4812	01030 N04812	01030 4812	250	1.500
	14	01030 BL4814	01030 N04814	01030 4814	250	1.500
	16	01030 BL4816	01030 N04816	01030 4816	250	1.500
	18	01030 BL4818	01030 N04818	01030 4818	200	1.200
	21	01030 BL4821	01030 N04821	01030 4821	200	1.200
	24	01030 BL4824	01030 N04824	01030 4824	150	900
	27	01030 BL4827	01030 N04827	01030 4827	150	900
	30	01030 BL4830	01030 N04830	01030 4830	150	900
	35	01030 BL4835	01030 N04835	01030 4835	100	600
	4,8	10	01040 BL4810	01040 N04810	01040 4810	250
12		01040 BL4812	01040 N04812	01040 4812	250	1.500
14		01040 BL4814	01040 N04814	01040 4814	200	1.200
16		01040 BL4816	01040 N04816	01040 4816	200	1.200
18		01040 BL4818	01040 N04818	01040 4818	200	1.200
21		01040 BL4821	01040 N04821	01040 4821	150	900
27		01040 BL4827	01040 N04827	01040 4827	150	900

HLINÍK/NEREZOVÁ OCEL A2

STANDARDNÍ NÝTY
Plochá hlava

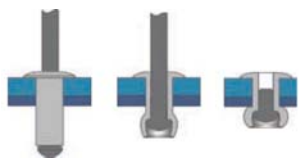





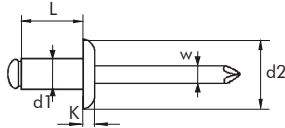

TĚLO: Hliník Al Mg 3,5

TRN: Nerezová ocel A2/304



Testováno dle EN ISO 14589

d1 Ø m/m	L Nominalní m/m	 m/m	d2 Ø m/m	K m/m	W Ø m/m	BALENÍ		 E m/m MIN. MÁX.	 (N)	 (N)	Kód zboží							
						 vnitřní	 veknovní											
2,4	4	2,50	5,00	0,60	1,45	1.000	8.000	0,5 - 2,0	350	550	01019002404							
	5					1.000	8.000	2,0 - 4,0			01019002405							
	6					1.000	8.000	2,5 - 4,0			01019002406							
	8					1.000	8.000	4,0 - 6,0			01019002408							
	10					1.000	8.000	6,0 - 8,0			01019002410							
3,0	8	3,10	6,00	1,00	1,80	500	4.000	3,5 - 5,0	550	850	01019003008							
	10					500	4.000	5,0 - 7,0			01019003010							
3,2	6	3,30	6,40	1,00	1,80	500	4.000	1,5 - 3,5	750	1100	01019003206							
	8					500	4.000	3,5 - 5,0			01019003208							
	10					500	4.000	5,0 - 7,0			01019003210							
	12					500	4.000	7,0 - 9,0			01019003212							
	15					500	4.000	9,0 - 12,0			01019003215							
	18					500	4.000	12,0 - 15,0			01019003218							
	20					500	4.000	15,0 - 17,0			01019003220							
4,0	6	4,10	8,00	1,40	2,20	500	4.000	1,0 - 3,0	1250	1800	01019004006							
	8					500	4.000	3,0 - 5,0			01019004008							
	10					500	4.000	5,0 - 6,5			01019004010							
	12					500	3.000	6,5 - 8,5			01019004012							
	14					500	3.000	8,5 - 10,5			01019004014							
	16					500	3.000	10,5 - 12,5			01019004016							
	18					500	3.000	12,5 - 14,5			01019004018							
	20					500	3.000	14,5 - 16,5			01019004020							
	25					250	1.500	16,5 - 21,5			01019004025							
	4,8					6	4,90	9,50			1,50	2,65	500	3.000	0,5 - 3,0	1850	2600	01019004806
						8							500	3.000	3,0 - 4,5			01019004808
10		500	3.000	4,5 - 6,0	01019004810													
12		500	3.000	6,0 - 8,0	01019004812													
14		250	2.000	8,0 - 10,0	01019004814													
16		250	2.000	10,0 - 12,0	01019004816													
18		250	1.500	12,0 - 14,0	01019004818													
21		250	1.500	14,0 - 17,0	01019004821													
24		200	1.200	17,0 - 20,0	01019004824													
30		200	1.200	23,0 - 25,0	01019004830													
35		150	900	25,0 - 30,0	01019004835													
40		150	900	30,0 - 35,0	01019004840													
5,0		8	5,10	9,50	1,60	2,65			500	3.000			3,0 - 4,5	2150	3000			01019005008
		10							500	3.000			4,5 - 6,0					01019005010
	12	500					3.000	6,0 - 8,0	01019005012									
	14	250					2.000	8,0 - 10,0	01019005014									
	16	250					2.000	10,0 - 12,0	01019005016									
	18	250					1.500	12,0 - 14,0	01019005018									
	20	250					1.500	14,0 - 16,0	01019005020									
	25	200					1.200	16,0 - 21,0	01019005025									
	30	200					1.200	21,0 - 25,0	01019005030									
	35	150					900	25,0 - 30,0	01019005035									
	40	150					900	30,0 - 35,0	01019005040									
	45	100					600	35,0 - 40,0	01019005045									
	50	100					600	40,0 - 45,0	01019005050									
	6,0	8					6,10	12,00	1,80	3,20	250	2.000	2,0 - 3,0			3200	4600	01019006008
10		250	1.500	3,0 - 5,0	01019006010													
12		250	1.500	5,0 - 7,0	01019006012													
14		250	1.500	7,0 - 9,0	01019006014													
16		250	1.500	9,0 - 11,0	01019006016													
18		200	1.200	11,0 - 13,0	01019006018													
20		200	1.200	13,0 - 15,0	01019006020													

Pozn: Na dotaz umíme nabídnout výrobu nýtů hliníku/nerez se zapuštěnou hlavou.
Pro informace ohledně minimálního množství a dodacího termínu nás prosím kontaktujte.

STANDARDNÍ NÝTY

Velká hlava

HLINÍK/NEREZOVÁ OCEL A2



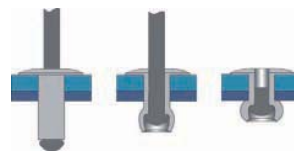
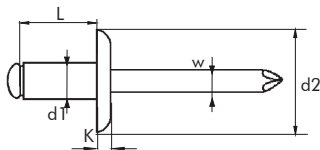

TĚLO: Hliník Al Mg 3,5

TRN: Nerezová ocel A2/304





Testováno dle EN ISO 14589

d1 mm	L Nominalní mm	 mm	d2 mm	K mm	W mm	BALENÍ		E mm		(N)	(N)	Kód zboží
						 vnitřní	 velkovýň	MIN.	MÁX.			
4,0	8	4,10	12,00	1,40	2,20	500	3.000	1,5 -	5,0	1250	1800	01049004008
	10					500	3.000	5,0 -	6,5			01049004010
	12					250	2.000	6,5 -	8,5			01049004012
	14					250	2.000	8,5 -	10,5			01049004014
	16					250	2.000	10,5 -	12,5			01049004016
	18					250	2.000	12,5 -	14,5			01049004018
	20					200	2.000	14,5 -	16,5			01049004020
4,8	21	4,90	11,00	1,60	2,65	250	1.500	14,0 -	17,0	1850	2600	01038004821
4,8	10	4,90	14,00	1,80	2,65	250	1.500	3,5 -	6,0	1850	2600	01039004810
	12					250	1.500	6,0 -	8,0			01039004812
	14					250	1.500	8,0 -	10,0			01039004814
	16					250	1.500	10,0 -	12,0			01039004816
	18					200	1.200	12,0 -	14,0			01039004818
	21					200	1.200	14,0 -	17,0			01039004821
	24					150	900	17,0 -	20,0			01039004824
	27					150	900	20,0 -	23,0			01039004827
	30					150	900	23,0 -	25,0			01039004830
35	150	600	25,0 -	30,0	01039004835							
4,8	10	4,90	16,00	1,80	2,65	250	1.500	4,5 -	6,0	1850	2600	01049004810
	12					250	1.500	6,0 -	8,0			01049004812
	14					200	1.200	8,0 -	10,0			01049004814
	16					200	1.200	10,0 -	12,0			01049004816
	18					200	1.200	12,0 -	14,0			01049004818
	21					150	900	14,0 -	17,0			01049004821
	24					150	900	17,0 -	20,0			01049004824
	27					150	900	20,0 -	23,0			01049004827
	30					150	900	23,0 -	25,0			01049004830
	35					100	600	25,0 -	30,0			01049004835
5,0	8	5,10	11,00	1,60	2,65	250	2.000	3,0 -	4,5	2150	3100	01038005008
	10					250	2.000	4,5 -	6,0			01038005010
	12					250	2.000	6,0 -	8,0			01038005012
	14					250	1.500	8,0 -	10,0			01038005014
	16					250	1.500	10,0 -	12,0			01038005016
	18					250	1.500	12,0 -	14,0			01038005018
	20					250	1.500	14,0 -	16,0			01038005020
	25					250	1.500	16,0 -	21,0			01038005025
30	200	1.200	21,0 -	25,0	01038005030							
5,0	8	5,10	14,00	1,80	2,65	250	1.500	3,0 -	4,5	2150	3100	01039005008
	10					250	1.500	4,5 -	6,0			01039005010
	12					250	1.500	6,0 -	8,0			01039005012
	14					250	1.500	8,0 -	10,0			01039005014
	16					250	1.500	10,0 -	12,0			01039005016
	18					200	1.200	12,0 -	14,0			01039005018
	20					200	1.200	14,0 -	16,0			01039005020
	25					150	900	16,0 -	21,0			01039005025
	30					150	900	21,0 -	25,0			01039005030

HLINÍK/NEREZOVÁ OCEL A2



STANDARDNÍ BAREVNÉ NÝTY Velká hlava

d1 Ø m/m	L Nominalní m/m	BALENÍ		BARVENO BARVY Kód zboží
		 vnitřní	 veškovní	
3,2	6	500	4.000	01019 3206
	8	500	4.000	01019 3208
	10	500	4.000	01019 3210
	12	500	4.000	01019 3212
	15	500	4.000	01019 3215
	18	500	4.000	01019 3218
4,0	6	500	4.000	01019 4006
	8	500	4.000	01019 4008
	10	500	4.000	01019 4010
	12	500	3.000	01019 4012
	14	500	3.000	01019 4014
	16	500	3.000	01019 4016
4,8	6	500	3.000	01019 4806
	8	500	3.000	01019 4808
	10	500	3.000	01019 4810
	12	500	3.000	01019 4812
	14	250	2.000	01019 4814
	16	250	2.000	01019 4816
	18	250	1.500	01019 4818
	21	250	1.500	01019 4821
	24	200	1.200	01019 4824
	30	200	1.200	01019 4830
	35	150	900	01019 4835



HLINÍK/NEREZOVÁ OCEL A2

STANDARDNÍ BAREVNÉ NÝTY Velká hlava

d1 Ø m/m	L Nominalní m/m	BALENÍ		BARVENO BARVY Kód zboží	d2 Ø m/m
		 vnitřní	 veškovní		
4,8	10	250	1.500	01039 4810	14
	12	250	1.500	01039 4812	
	14	250	1.500	01039 4814	
	16	250	1.500	01039 4816	
	18	200	1.200	01039 4818	
	21	200	1.200	01039 4821	
	24	150	900	01039 4824	
	27	150	900	01039 4827	
	30	150	900	01039 4830	
	35	150	600	01039 4835	
4,8	10	250	1.500	01049 4810	16
	12	250	1.500	01049 4812	
	14	200	1.200	01049 4814	
	16	200	1.200	01049 4816	
	18	200	1.200	01049 4818	
	21	150	900	01049 4821	
	24	150	900	01049 4824	
	27	150	900	01049 4827	
	30	150	900	01049 4830	
	35	100	600	01049 4835	
5,0	8	250	2.000	01039 5008	14
	10	250	1.500	01039 5010	
	12	250	1.500	01039 5012	
	14	250	1.500	01039 5014	
	16	250	1.500	01039 5016	
	18	200	1.200	01039 5018	
	20	200	1.200	01039 5020	
	25	150	900	01039 5025	
	30	150	900	01039 5030	



STANDARDNÍ NÝTY

Plochá hlava

HLINÍK/HLINÍK





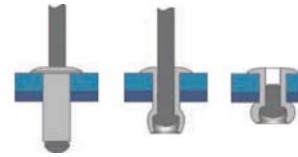
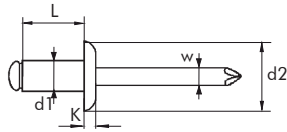

TĚLO: Hliník Al Mg Si

TRN: Hliník



Testováno dle EN ISO 14589

d1 Ø mm	L Nominální mm	 mm	d2 Ø mm	K mm	W Ø mm	BALENÍ		E mm		 (N)	 (N)	Kód zboží
						 vnitřní	 veškovní	MIN.	MÁX.			
3,2	6	3,30	6,40	1,00	1,95	500	4.000	1,5	3,5	450	550	01160003206
	8					500	4.000	3,5	5,0			01160003208
	10					500	4.000	5,0	7,0			01160003210
	12					500	4.000	7,0	9,0			01160003212
	15					500	4.000	9,0	12,0			01160003215
	18					500	3.000	12,0	15,0			01160003218
4,0	6	4,10	8,00	1,20	2,45	500	4.000	1,0	3,0	680	800	01160004006
	8					500	4.000	3,0	5,0			01160004008
	10					500	4.000	5,0	6,5			01160004010
	12					500	3.000	6,5	8,5			01160004012
	14					500	3.000	8,5	10,5			01160004014
	16					500	3.000	10,5	12,5			01160004016
	18					500	3.000	12,5	14,5			01160004018
	20					500	3.000	14,5	16,5			01160004020
4,8	6	4,90	9,50	1,50	2,95	500	3.000	0,5	3,0	950	1200	01160004806
	8					500	3.000	2,5	4,0			01160004808
	10					500	3.000	4,0	6,0			01160004810
	12					500	3.000	6,0	8,0			01160004812
	14					250	2.000	8,0	10,0			01160004814
	16					250	2.000	10,0	12,0			01160004816
	18					250	1.500	12,0	14,0			01160004818
	21					250	1.500	14,0	17,0			01160004821
	24					200	1.200	17,0	20,0			01160004824
		27					200	1.200	20,0	23,0		

Pozn: Na dotaz umíme nabídnout výrobu nýtu hliník/hliník se zapuštěnou hlavou (d2).

STANDARDNÍ NÝTY

Plochá hlava

HLINÍK/HLINÍK





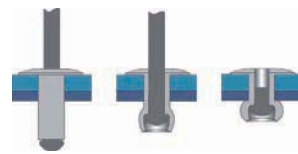
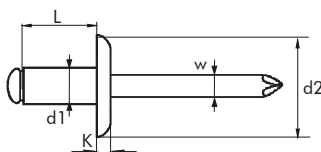

TĚLO: Hliník Al Mg Si

TRN: Hliník



Testováno dle EN ISO 14589

d1 Ø mm	L Nominální mm	 mm	d2 Ø mm	K mm	W Ø mm	BALENÍ		E mm		 (N)	 (N)	Kód zboží
						 vnitřní	 veškovní	MIN.	MÁX.			
4,8	10	4,90	14,00	1,80	2,95	250	1.500	4,0	6,0	950	1200	01180004810
	12					250	1.500	6,0	8,0			01180004812
	14					250	1.500	8,0	10,0			01180004814
	16					250	1.500	10,0	12,0			01180004816
	18					200	1.200	12,0	14,0			01180004818
	21					200	1.200	14,0	17,0			01180004821
	24					150	900	17,0	20,0			01180004824
4,8	10	4,90	16,00	1,80	2,95		1.500	4,0	6,0	950	1200	G1184004810

VÍCESVĚRNÉ NÝTY MULTIGRIP



VÍCESVĚRNÝ NÝT MULTIGRIP

Široký svěrný rozsah.
Úhledné z obou stran aplikace.
Perfektně vyplní otvor a toleruje nepřesnosti v předvrtání.
Obzvláště vhodný pro aplikace s výskytem plastů a tenkých kovových materiálů.



OCHRANNÉ POVRCHOVÉ ÚPRAVY

Pro maximální odolnost vůči korozi a trvanlivost našich ocelových nýtů používáme různé povrchové úpravy, jako zinkování nebo ekologické povrchové úpravy Delta Seal či Delta Protpekt.

Další možností je anodizování. Tyto úpravy jsou možné pro hliníkové díly a chrání nýty před oděrem a působením solných korozních prvků. Tyto úpravy rovněž umožňují následné lakování.

Při výrobě speciální produktů BRALO úzce spolupracuje se zákazníkem, aby vyhovělo všem specifickým požadavkům každé aplikace.

POVRCHOVÉ ÚPRAVY A PASIVACE	VZHLED	KOROZNÍ PROSTŘEDÍ
Anodizace	Stříbrný nebo černý	Silné
Lakování (epoxy)	Podle barvy	Lehké
Delta-Seal šedá	Šedá	Silné
Delta-Seal černá	Černá	Silné

VÍCESVĚRNÉ NÝTY MULTIGRIP

Plochá hlava

HLINÍK/OCEL



TĚLO: Hliník Al Mg 3,5
TRN: Pozinkovaná ocel A1K

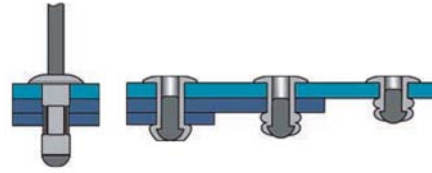
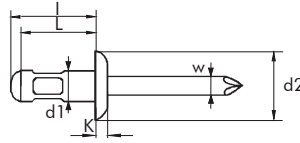

Testováno dle EN ISO 14589

d1 Ø m/m	L Nominalní m/m		d2 Ø m/m	K m/m	W Ø m/m	BALENÍ		I (MÁX.) m/m	E m/m				Kód zboží
									MIN.	MÁX.			
3,2	8,0	3,30-3,50	6,20	1,10	1,80	500	4.000	10,10	0,5	5,0	630	980	01080003208
	9,5					500	4.000	11,60	1,5	6,5			01080003209
	11,0					500	4.000	13,10	4,0	8,0			01080003211
4,0	6,8	4,10-4,30	8,20	1,40	2,20	500	4.000	10,00	0,5	3,5	1050	1400	01080004008
	9,5					500	3.000	12,00	1,0	4,0			01080004009
	11,0					500	3.000	13,00	2,0	6,0			01080004011
	12,5					500	3.000	15,00	4,0	9,0			01080004012
	16,5					500	3.000	19,00	6,0	13,0			01080004016
4,8	10,5	4,90-5,10	9,90	1,60	2,75	250	2.000	14,00	1,5	6,5	1500	2300	01080004810
	15,0					250	2.000	18,00	4,5	11,0			01080004815
	16,5					250	1.500	20,00	6,5	12,5			01080004816
	19,5					250	1.500	23,00	8,5	14,5			01080004819
	24,5					200	1.200	28,00	12,5	20,0			01080004824



d1 Ø mm	L Nominalní mm	BARVENO BÍLE	BARVENO ČERNÉ RAL 9005	OSTATNÍ BARVY	BALENÍ	
		Kód zboží	Kód zboží	Kód zboží		
3,2	8,5	01080 BL3208	01080 N03208	01080 3208	500	4.000
	11,0	01080 BL3211	01080 N03211	01080 3211	500	4.000
4,0	6,8	01080 BL40068	01080 N040068	01080 40068	500	4.000
	9,5	01080 BL4009	01080 N04009	01080 4009	500	3.000
	12,5	01080 BL4012	01080 N04012	01080 4012	500	3.000
	16,5	01080 BL4016	01080 N04016	01080 4016	500	3.000
4,8	10,5	01080 BL4810	01080 N04810	01080 4810	250	2.000
	15,0	01080 BL4815	01080 N04815	01080 4815	250	2.000
	16,5	01080 BL4816	01080 N04816	01080 4816	250	1.500
	24,5	01080 BL4824	01080 N04824	01080 4824	200	1.200

VÍCESVĚRNÉ NÝTY MULTIGRIP

Plochá hlava

HLINÍK/OCEL



TĚLO: Hliník Al Mg 2,5
TRN: Pozinkovaná ocel A1K

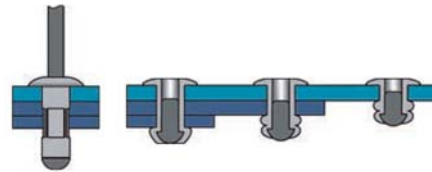
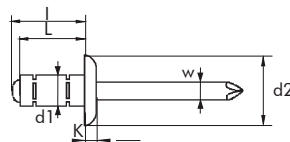

Testováno dle EN ISO 14589

d1 Ø mm	L Nominalní mm		d2 Ø mm	K mm	W Ø mm	BALENÍ		I Max. mm	E mm				Kód zboží
									MIN.	MÁX.			
6,4	12	6,50	13,00	1,80	3,60	250	1.500	17,00	1,0 - 6,0	2800	4000		01080006412
	15					200	1.200	20,00	4,0 - 9,0				01080006415
	18					200	1.200	23,00	6,0 - 12,0				01080006418

HLINÍK/OCEL



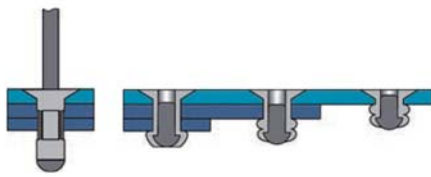

VÍCESVĚRNÉ NÝTY MULTIGRIP Zapuštěná hlava 120°

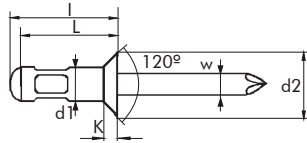

TĚLO: Hliník Al Mg 2,5
TRN: Pozinkovaná ocel A1K



Testováno dle EN ISO 14589

d1 Ø mm	L Nominální mm		d2 Ø mm	K mm	W Ø mm	BALENÍ		I Max. mm				Kód zboží	
						vnitřní	veškovní		MIN. E mm	MÁX.	(N)	(N)	
3,2	9,5	3,30-3,50	5,80	1,10	1,80	500	4.000	11,00	1,5 - 6,0	630	980	01090003209	
4,0	11,0	4,10-4,30	7,30	1,30	2,20	500	3.000	14,00	2,0 - 8,0	1050	1400	01090004011	
4,8	12,0	4,90-5,10	8,80	1,60	2,75	250	2.000	16,00	2,0 - 7,5	1500	2400	01090004812	
	250					1.500	20,00	6,0 - 12,0			01090004816		

d1 Ø m/m	L Nominální m/m	OSTATNÍ BARVY Kód zboží	BALENÍ	
			vnitřní	veškovní
3,2	9,0	01090 3209	500	4.000
4,0	11,0	01090 4011	500	3.000
4,8	12,0	01090 4812	250	2.000
	16,0	01090 4816	250	1.500

HLINÍK/OCEL



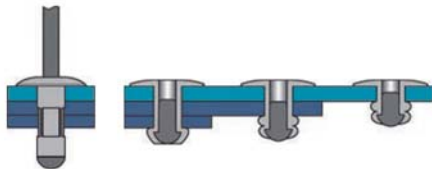

VÍCESVĚRNÉ NÝTY MULTIGRIP Velká hlava

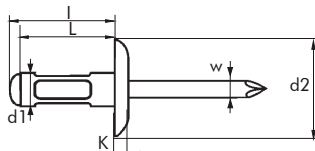

TĚLO: Hliník Al Mg 2,5
TRN: Pozinkovaná ocel A1K



Testováno dle EN ISO 14589

d1 Ø mm	L Nominální mm		d2 Ø mm	K mm	W Ø mm	BALENÍ		I Max. mm				Kód zboží	
						vnitřní	veškovní		MIN. E mm	MÁX.	(N)	(N)	
3,2	8,0	3,30-3,50	9,5	1,10	1,80	500	4.000	10,00	0,5 - 5,0	630	980	01100003208	
4,0	13,0	4,10-4,30	12,0	1,40	2,20	250	2.000	15,30	3,0 - 9,0	1050	1500	01100004013	
	250					2.000	18,80	6,0 - 13,0			01100004016		
4,8	10,5	4,90-5,10	16,0	1,80	2,75	150	900	14,00	1,5 - 6,0	1500	2400	01100004810	
	150					900	20,00	6,0 - 12,5			01100004817		
	100					600	28,00	12,0 - 19,5			01100004825		

d1 Ø mm	L Nominální mm	BARVENO BÍLE Kód zboží	BARVENO ČERNĚ RAL 9005 Kód zboží	OSTATNÍ BARVY Kód zboží	BALENÍ	
					vnitřní	veškovní
4,0	13,0	01100 BL4013	01100 N04013	01100 4013	250	2.000
	16,0	01100 BL4016	01100 N04016	01100 4016	250	2.000
4,8	10,5	01100 BL4810	01100 N04810	01100 4810	150	900
	17,0	01100 BL4817	01100 N04817	01100 4817	150	900
	25,0	01100 BL4825	01100 N04825	01100 4825	100	600



VÍCESVĚRNÉ NÝTY MULTIGRIP

Plochá hlava





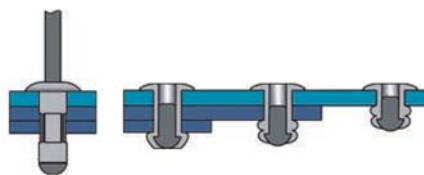
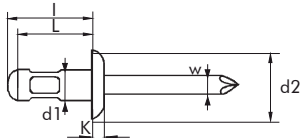

HLINÍK/NEREZOVÁ OCEL





TĚLO: Hliník Al-Mg 2,5
TRN: Nerezová ocel A2/304



Testováno dle EN ISO 14589

d1 Ø mm	L Nominiální mm	 mm	d2 Ø mm	K mm	W Ø mm	BALENÍ		I Max. mm	 mm MIN. MÁX.	 (N)	 (N)	Kód zboží
						 vnitřní	 veknovní					
3,2	8,0	3,30-3,50	6,20	1,10	1,80	500	4.000	10,50	0,5 - 5,0	650	1000	01089003208
	11,0					500	4.000	13,00	4,0 - 8,0			01089003211
4,0	6,8	4,10-4,30	8,20	1,40	2,20	500	4.000	10,00	0,5 - 3,5	1050	1500	010890040068
	9,5					500	3.000	12,00	1,0 - 6,0			01089004009
	12,5					500	3.000	15,00	4,0 - 9,0			01089004012
	16,5					500	3.000	19,00	6,0 - 13,0			01089004016
4,8	10,5	4,90-5,10	9,90	1,80	2,75	250	2.000	14,00	1,5 - 6,5	1500	2300	01089004810
	15,0					250	2.000	18,00	4,5 - 11,0			01089004815
	16,5					250	1.500	20,00	6,5 - 12,5			01089004816
	24,5					200	1.200	28,00	12,5 - 20,0			01089004824



d1 Ø m/m	L Nominiální m/m	BALENÍ		OSTATNÍ BARVY	
		 vnitřní	 veknovní	Kód zboží	
3,2	8,0	500	4.000	01089	3208
	11,0	500	4.000	01089	3211
4,0	6,8	500	4.000	01089	40068
	9,5	500	3.000	01089	4009
	12,5	500	3.000	01089	4012
	16,5	500	3.000	01089	4016
4,8	10,5	250	2.000	01089	4810
	15,0	250	2.000	01089	4815
	16,5	250	1.500	01089	4816
	19,5	200	1.200	01089	4819
	24,5	200	1.200	01089	4824

HLINÍK/NEREZOVÁ OCEL

VÍCESVĚRNÉ NÝTY MULTIGRIP Zapuštěná hlava 120°

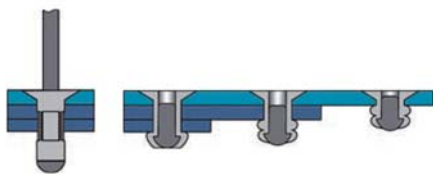

TĚLO: Hliník Al Mg 2,5
TRN: Nerezová ocel A2/304

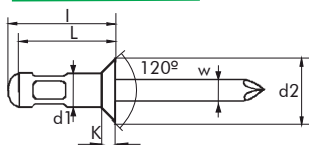

Testováno dle EN ISO 14589

d1 Ø mm	L Nominalní mm		d2 Ø mm	K mm	W Ø mm	BALENÍ		I Max. mm				Kód zboží
		mm				vnitřní	veškovní		E mm	(N)	(N)	
									MIN. MÁX.			
3,2	9,5	3,30-3,50	5,80	1,10	1,80	500	4.000	11,00	1,5 - 6,0	700	980	01099003209
4,0	11,0	4,10-4,30	7,30	1,30	2,20	500	3.000	12,80	2,0 - 8,0	1200	1600	01099004011
4,8	12,0	4,90-5,10	8,80	1,60	2,75	500	3.000	14,20	2,0 - 7,5	1500	2400	01099004812
	16,5					250	1.500	18,70	6,0 - 12,0			01099004816

d1 Ø m/m	L Nominal m/m	BALENÍ		OSTATNÍ BARVY	
		vnitřní	veškovní	Kód zboží	
3,2	9,5	500	4.000	01099	3209
4,0	11,0	500	3.000	01099	4011
4,8	12,0	250	2.000	01099	4812
	16,5	250	1.500	01099	4816

HLINÍK/NEREZOVÁ OCEL

VÍCESVĚRNÉ NÝTY MULTIGRIP Velká hlava

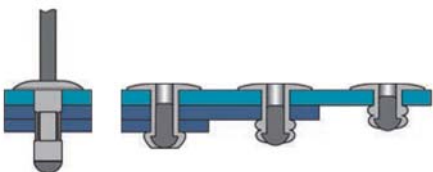

TĚLO: Hliník Al Mg 2,5
TRN: Nerezová ocel A2/304

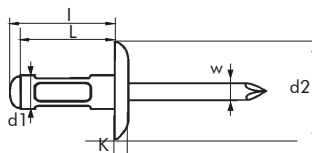

Testováno dle EN ISO 14589

d1 Ø mm	L Nominalní mm		d2 Ø mm	K mm	W Ø mm	BALENÍ		I Max. mm				Kód zboží
		mm				vnitřní	veškovní		E mm	(N)	(N)	
									MIN. MÁX.			
4,8	10,5	4,90-5,10	16,0	1,80	2,75	200	1.200	14,00	1,5 - 6,0	1500	2400	01109004810
	17,0					150	900	20,00	6,0 - 12,5			01109004817
	19,0					150	900	22,00	8,5 - 14,5			01109004819
	25,0					100	600	28,00	12,0 - 19,5			01109004825

d1 Ø m/m	L Nominalní m/m	BALENÍ		OSTATNÍ BARVY	
		vnitřní	veškovní	Kód zboží	
4,8	10,5	150	900	01109	4810
	17,0	150	900	01109	4817
	25,0	100	600	01109	4825

VROUBKOVANÉ NÝTY

Možnost použití pro slepé díry (neprůchozí)
Vhodné pro spojení kovu se dřevem či plasty.
Poskytuje odolné spojení



VROUBKOVANÉ NÝTY Plochá hlava





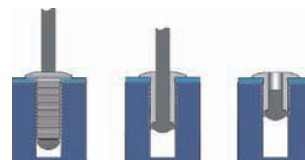
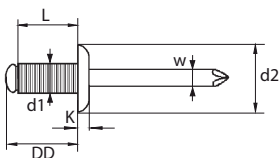

HLINÍK/OCEL



TĚLO: Hliník Al Mg 3,5
TRN: Pozinkovaná ocel A1K



Testováno dle EN ISO 14589

d1 Ø mm	L Nominalní mm	 mm	d2 Ø mm	K mm	W Ø mm	BALENÍ		 E mm MIN. MÁX.	 (N)	 (N)	Kód zboží	DD (Drill Depth) mm
						 vnitřní	 veknovní					
3,2	10	3,50	6,50	0,80	1,80	500	4.000	6,0	700	1100	01700003210	13
4,0	8	4,30	8,00	1,00	2,20	500	4.000	4,0	900	1400	01700004008	11
	12					500	3.000	6,0			01700004012	15
	16					500	3.000	8,0			01700004016	19
4,8	8	5,10	9,50	1,10	2,73	500	3.000	4,0	1600	2600	01700004808	11
	10					250	2.000	6,0			01700004810	13
	12					250	2.000	8,0			01700004812	15
	14					250	2.000	10,0			01700004814	17
	18					250	1.500	13,0			01700004818	21
	21					250	1.500	15,0			01700004821	24
	24					200	1.200	20,0			01700004824	27

NÝTY SOFT DO MĚKKÉHO MATERIÁLU

Vhodné pro spojování měkkých a křehkých materiálů.
Nedeformuje povrch nýtovaného materiálu.
Dobrá odolnost na tahu i stříhu je zachována.



HLINÍK/OCEL

NÝTY SOFT DO MĚKKÉHO MATERIÁLU Plochá hlava

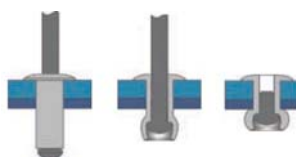



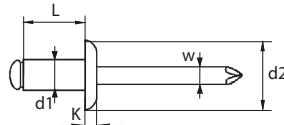

TĚLO: Hliník Al Mg 3,5

TRN: Ocel



Testováno dle EN ISO 14589

d1 Ø mm	L Nominální mm	 mm	d2 Ø mm	K mm	W Ø mm	BALENÍ				Kód zboží	
						 vnitřní	 veknovní	MIN. mm	MÁX. mm		(N)
4,0	6	4,10	8,00	1,40	2,20	4.000		1,5 - 3,0	1200	1800	G1350004006
	8					4.000		3,0 - 5,0			G1350004008
	10					4.000		5,0 - 6,5			G1350004010
	12					4.000		6,5 - 8,5			G1350004012
	14					4.000		8,5 - 10,5			G1350004014
	16					4.000		10,5 - 12,5			G1350004016
	18					4.000		12,5 - 14,5			G1350004018
	20					4.000		14,5 - 16,5			G1350004020
4,8	6	4,90	9,50	1,50	2,73	4.000		0,5 - 3,0	2000	2700	G1350004806
	8					3.500		3,0 - 4,5			G1350004808
	10					3.500		4,5 - 6,0			G1350004810
	12					3.000		6,0 - 8,0			G1350004812
	14					2.500		8,0 - 10,0			G1350004814
	16					2.500		10,0 - 12,0			G1350004816
	18					2.000		12,0 - 14,0			G1350004818
	21					2.000		14,0 - 17,0			G1350004821
	24					1.500		17,0 - 20,0			G1350004824
	27					1.500		20,0 - 23,0			G1350004827
	30					1.000		23,0 - 25,0			G1350004830
	32					1.000		25,0 - 27,0			G1350004832
5,0	10	5,10	8,00	1,10	2,65	3.500		4,5 - 6,0	2250	3000	G1350005010
	14					2.500		8,0 - 10,0			G1350005014
	16					2.500		10,0 - 12,0			G1350005016
	25					1.500		16,0 - 21,0			G1350005025
	30					1.500		21,0 - 25,0			G1350005030
6,0	18	6,10	12,00	1,50	3,20	1.500		11,0 - 13,0	2500	3300	G1350006018

SLUPKOVÉ NÝTY

Vytváří široce rozevřený tvar z druhé strany aplikace (banánová slupka).

Ideální pro použití v aplikacích s měkkým nebo málo odolným materiálem.

Možno použít pro nadrozměrné otvory.

Rozkládá sílu sevření do široké oblasti

(nedeformuje materiál v aplikaci).



SEVŘENÍ ROZLOŽENÉ DO ČTYŘ LÍSTKŮ



Trhací nýt z hliníkové slitiny s velkou plochou sevření rozložené do čtyř lístků. Slupkové nýty BRALO jsou ideální pro aplikace s plasty, či materiály s nízkou odolností vůči tlaku.



Slupkové nýty nabízíme v široké škále barevného provedení.

Od černé po bílou, umíme nabídnout přes 100 barev dle vzorníku RAL na základě poptávky.



d1 Ø m/m	L Nominalní m/m	OSTATNÍ BARVY Kód zboží	BALENÍ	
			 vnitřní	 veknovní
4,0	8	01130 4008	500	4.000
	10	01130 4010	500	4.000
	12	01130 4012	500	3.000
	14	01130 4014	500	3.000
	16	01130 4016	500	3.000
	18	01130 4018	500	3.000
	20	01130 4020	500	3.000
25	01130 4025	250	1.500	
4,8	10	01130 4810	500	3.000
	12	01130 4812	500	3.000
	14	01130 4814	250	2.000
	16	01130 4816	250	2.000
	18	01130 4818	250	1.500
	21	01130 4821	250	1.500
	24	01130 4824	200	1.200
	27	01130 4827	200	1.200
	30	01130 4830	200	1.200
	35	01130 4835	150	900

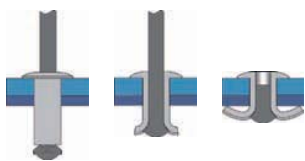





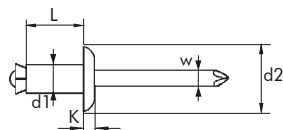

TĚLO: Hliník Al Mg 3,5

TRN: Pozinkovaná ocel A1K



Testováno dle EN ISO 14589

d1 Ø mm	L Nominalní mm	 mm	d2 Ø mm	K mm	W Ø mm	BALENÍ		 E mm	 (N)	 (N)	Kód zboží
						 vnitřní	 veškovní				
3,2	8	3,40	6,50	0,80	1,80	500	4.000	3,5	1000	1200	01130003208
	10					500	4.000	5,0			01130003210
	12					500	4.000	7,0			01130003212
	14					500	4.000	9,0			01130003214
	16					500	3.000	11,0			01130003216
	18					500	3.000	13,0			01130003218
4,0	8	4,20	8,00	1,00	2,20	500	4.000	4,0	1200	1400	01130004008
	10					500	4.000	6,0			01130004010
	12					500	3.000	8,0			01130004012
	14					500	3.000	10,0			01130004014
	16					500	3.000	12,0			01130004016
	18					500	3.000	14,0			01130004018
	20					500	3.000	16,0			01130004020
	25					250	1.500	21,0			01130004025
4,8	10	5,00	9,50	1,10	2,73	500	3.000	5,0	1800	2000	01130004810
	12					500	3.000	7,0			01130004812
	14					250	2.000	9,0			01130004814
	16					250	2.000	11,0			01130004816
	18					250	1.500	13,0			01130004818
	21					250	1.500	16,0			01130004821
	24					200	1.200	19,0			01130004824
	27					200	1.200	22,0			01130004827
	30					200	1.200	25,0			01130004830
	32					200	1.200	27,0			01130004832
	35					150	900	30,0			01130004835
	40					150	900	32,0			01130004840
	45					100	600	37,0			01130004845
	50					100	600	42,0			01130004850
	5,0*	40	5,20	9,30	1,50	2,73	150	900	32,0	2000	2100
45						100	600	37,0			01130005045
50						100	600	42,0			01130005050
55						100	600	47,0			01130005055
60						500		52,0			01130005060
65						500		57,0			01130005065
70						500		62,0			01130005070
75						500		68,0			01130005075
80						500		72,0			01130005080
90						500		80,0			01130005090
100						500		90,0			01130005100
110						500	100,0				011300050110
120						500	110,0				011300050120
130						250	120,0				011300050130
140						250	130,0				011300050140
150						250	140,0				011300050150
160						250	150,0				011300050160
170						250	160,0				011300050170
180					250	170,0				011300050180	
190					250	180,0				011300050190	
6,4*	35	6,60	13,00	2,00	3,50	100	600	25,0	2450	3500	01130006435
	50					500		40,0			01130006450
	75					500		65,0			01130006475
	80					250		70,0			01130006480
	100					250		90,0			011300064100
	120					250		110,0			011300064120
	125					250		115,0			011300064125
	150					250		140,0			011300064150
	175					200		165,0			011300064175
	190					200		180,0			011300064200

*Pozn: Slupkové nýty s hliníkovým tělem Al Mg3.

SLUPKOVÉ NÝTY

Velká hlava



HLINÍK/OCEL

TĚLO: Hliník Al Mg 3,5

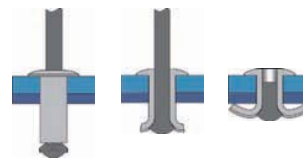
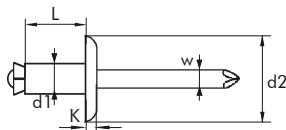

TRN: Pozinkovaná ocel A1K



Testováno dle EN ISO 14589

d1 Ø mm	L Nominalní mm		d2 Ø mm	K mm	W Ø mm	BALENÍ		E mm		(N)	(N)	Kód zboží
						 vnitřní	 veknovní	MIN.	MÁX.			
4,0	8	4,20	12,00	1,40	2,20	500	3.000	4,0	1450	1750		01150004008
	10					500	3.000	6,0				01150004010
	12					250	2.000	8,0				01150004012
	14					250	2.000	10,0				01150004014
	16					250	1.500	12,0				01150004016
	18					250	1.500	14,0				01150004018
	20					250	1.500	16,0				01150004020
4,8	10	5,00	14,00	1,80	2,73	250	1.500	5,0	1800	2000		01140004810
	12					250	1.500	7,0				01140004812
	14					250	1.500	9,0				01140004814
	16					250	1.500	11,0				01140004816
	18					200	1.200	13,0				01140004818
	21					200	1.200	16,0				01140004821
	24					150	900	19,0				01140004824
	27					150	900	22,0				01140004827
	30					150	900	25,0				01140004830
	35					100	600	30,0				01140004835
4,8	10	5,00	11,00	1,80	2,73	250	2.000	5,0	1800	2000		01131004810
	21					250	1.500	16,0				01131004821



d1 Ø mm	L Nominalní mm	BARVENO ČERNĚ RAL 9005		OSTATNÍ BARVY		BALENÍ	
		Kód zboží		Kód zboží		 vnitřní	 veknovní
4,0	8	01140	N04008	01140	4008	500	3.000
	10	01140	N04010	01140	4010	500	3.000
	12	01140	N04012	01140	4012	250	2.000
	14	01140	N04014	01140	4014	250	2.000
	16	01140	N04016	01140	4016	250	1.500
	18	01140	N04018	01140	4018	250	1.500
	20	01140	N04020	01140	4020	250	1.500
4,8	10	01140	N04810	01140	4810	250	1.500
	12	01140	N04812	01140	4812	250	1.500
	14	01140	N04814	01140	4814	250	1.500
	16	01140	N04816	01140	4816	250	1.500
	18	01140	N04818	01140	4818	200	1.200
	21	01140	N04821	01140	4821	200	1.200
	24	01140	N04824	01140	4824	150	900
	27	01140	N04827	01140	4827	150	900
	30	01140	N04830	01140	4830	150	900
	35	01140	N04835	01140	4835	100	600

ROZPĚRNÉ NÝTY TREBOL

Široký svěrný rozsah.

Vysoká odolnost vůči korozi.

Trn uzavřen v nýtu (po zanýtování nevypadne).

Vytvořen ke spojování pevných materiálů k měkkým, nebo k materiálům s menší odolností.



SEVŘENÍ ROZLOŽENÉ NA TŘI ČÁSTI

Bralo Rozpěrný nýt TREBOL je druh trhacího nýtu vytvořený pro rychlé a jednoduché spojení tvrdých materiálů s měkkými, či málo odolnými materiály. Tento nýt se při aplikaci roztáhne do třech částí, které rozloží sílu sevření do větší plochy, čímž se snižuje riziko poškození spojovaných materiálů.

Verze S-Trebol poskytuje vyšší pevnost na tahu a stříhu a může být použit pro větší velikosti otvorů.



Tento nýt také disponuje neoprenovou podložkou, díky které má skvělé těsnící vlastnosti.

Bralo trhací nýt rozpěrný těsnící S-Trebol je schválený Německým institutem DIBt (Deutsches Institut für Bautechnik).

ROZPĚRNÉ NÝTY TREBOL

Plochá hlava

HLINÍK/HLINÍK







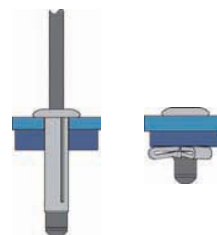
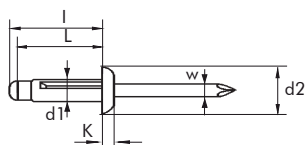

TĚLO: Hliník

TRN: Hliník



Testováno dle EN ISO 14589

d1 Ø mm	L Nominální mm	 mm	d2 Ø mm	K mm	W Ø mm	BALENÍ		I Max. mm	 E mm	 (N)	 (N)	Kód zboží
						 vnitřní	 veknovní					
4,0	10,5	4,20-4,50	8,00	1,40	2,40	250	2.000	12,30	0,5 - 2,5	730	950	01610004010
	13,6					250	2.000	15,40	1,0 - 3,0			01610004013
	18,8					250	2.000	20,60	1,0 - 7,0			01610004018
	20,4					250	1.500	22,20	1,0 - 8,5			01610004020
	24,5					250	1.500	26,30	4,0 - 12,0			01610004024
4,8	15,3	5,00-5,30	10,00	1,90	2,82	250	2.000	16,70	1,0 - 4,0	900	1150	01610004815
	20,5					250	1.500	21,90	1,0 - 9,0			01610004820
	24,5					200	1.200	25,90	4,0 - 12,0			01610004824
	28,0					200	1.200	29,40	6,0 - 16,0			01610004828

Pozn: Na dotaz umíme nabídnout výrobu Rozpěrných Trebol nýtů se zapuštěnou hlavou (d2).



d1 Ø mm	L Nominální mm	BARVENO BÍLE	BARVENO ČERNÉ RAL 9005	OSTATNÍ BARVY	BALENÍ	
		Kód zboží	Kód zboží	Kód zboží	 vnitřní	 veknovní
4,0	10,5	01610 BL4010	01610 N04010	01610 4010	250	2.000
	13,6	01610 BL4013	01610 N04013	01610 4013	250	2.000
	18,8	01610 BL4018	01610 N04018	01610 4018	250	2.000
	24,5	01610 BL4024	01610 N04024	01610 4024	250	1.500
4,8	15,3	01610 BL4815	01610 N04815	01610 4815	250	2.000
	20,5	01610 BL4820	01610 N04820	01610 4820	250	1.500
	24,5	01610 BL4824	01610 N04824	01610 4824	200	1.200

HLINÍK/HLINÍK

ROZPĚRNÉ NÝTY TREBOL Velká hlava

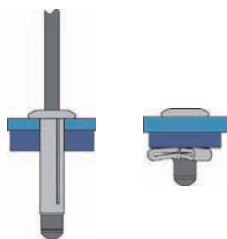





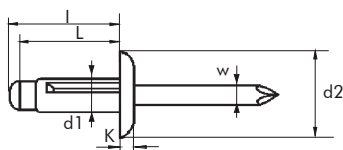

TĚLO: Hliník

TRN: Hliník



Testováno dle EN ISO 14589

d1 Ø mm	L Nominální mm	 mm	d2 Ø mm	K mm	W Ø mm	BALENÍ		I Max. mm	E MIN. mm MÁX.		 (N)	 (N)	Kód zboží
						 vnitřní	 veškovní		 (N)	 (N)			
4,0	18,8	4,20-4,50	12,00	1,50	2,40	250	2.000	20,60	1,0 - 7,0	700	850	01640004018	
4,8	20,5	5,00-5,30	14,00	1,90	2,82	200	1.200	21,90	1,0 - 9,0	900	1150	01630004820	
	200					1.200	25,90	4,0 - 12,0	01630004824				
4,8	20,5	5,00-5,30	16,00	1,80	2,82	200	1.200	21,90	1,0 - 9,0	900	1150	01640004820	

HLINÍK/HLINÍK

ROZPĚRNÉ TĚSNICÍ NÝTY S-TREBOL Plochá hlava

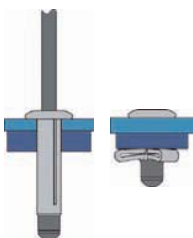





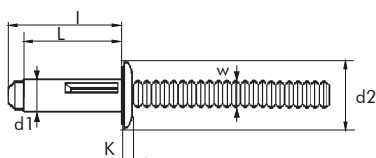

TĚLO: Hliník Al Mg 3,5

TRN: Hliník



Testováno dle EN ISO 14589

d1 Ø mm	L Nominální mm	 mm	d2 Ø mm	K mm	W Ø mm	BALENÍ		I Max. mm	E MIN. mm MÁX.		 (N)	 (N)	Kód zboží
						 vnitřní	 veškovní		 (N)	 (N)			
5,2	20,0*	5,30-5,60	11,40	2,00	3,10	250	1.500	23,75	0,5 - 5,1	3000	1700	01650005220	
	26,5					200	1.200	29,75	4,5 - 11,5				01650005226
6,4	23,5	6,50-6,70	14,00	2,60	3,40	150	900	28,50	1,5 - 6,5	4000	2500	01650006424	
7,7	28,0	7,90-8,30	19,00	4,00	4,40	500	35,00	35,00	1,5 - 9,5	4300	4800	G1654007828	

* Schváleno DIBt (Německým instutiem pro stavbu) N Z-14.1-4.

Pozn: Dostupné též (na poptání) bez neoprenové podložky.

TĚSNÍCÍ NÝTY

Vodotěsné a tlakotěsné.

Trn je uzavřen uvnitř nýtu (po zanýtování nevypadne).
Vhodné pro použití v elektrotechnice.



TĚSNÉ UZAVŘENÍ SPOJE

Bralo těsnicí nýt je synonymem bezpečí a spokojenosti

Těsnicí nýty jsou druhem trhacích nýtů, který zaručuje pevné spojení vysoké kvality. Spoj je zcela těsný vůči kapalinám, kdy nedochází k úniku jak kapalin, tak ani plynů a to díky trnu, který je uzavřen uvnitř hlavy nýtu.

Těsnicí nýty BRALO jsou nabízeny v mnoha průměrech od 3,2 mm do 6,4 mm a se svěrnými rozsahy v rozmezí od 0,5 mm do 20 mm.

Tyto nýty jsou dostupné v mnoha materiálových provedeních, ke kterým umíme nabídnout množství barevných provedení a ochranných povrchových úprav.



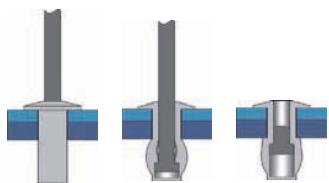





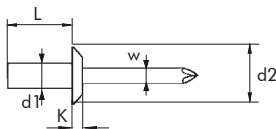

TĚLO: Hliník Al Mg 5



TRN: Lubrikovaná ocel



UNE - EN ISO 15973

Testováno dle EN ISO 14589

d1 Ø mm	L Nominalní mm		d2 Ø mm	K mm	W Ø mm	BALENÍ		 E mm MIN. MÁX.	 (N)	 (N)	Kód zboží
						 vnitřní	 veknovní				
3,2	6,5	3,30	6,40	1,00	1,65	500	4.000	0,5 - 2,0	1100	1450	01110003206
	8,0					500	4.000	2,0 - 3,5			01110003208
	9,5					500	4.000	3,5 - 5,0			01110003209
	11,0					500	4.000	5,0 - 6,5			01110003211
	12,5					500	4.000	6,5 - 8,0			01110003212
4,0	8,0	4,10	7,90	1,40	2,20	500	4.000	0,5 - 3,5	1600	2200	01110004008
	9,5					500	4.000	3,5 - 5,0			01110004010
	11,0					500	4.000	5,0 - 6,5			01110004011
	12,5					500	3.000	6,5 - 8,0			01110004013
	14,5					500	3.000	8,0 - 10,0			01110004015
4,8	8,5	4,90	9,30	1,70	2,65	500	3.000	0,5 - 3,5	2200	3100	01110004808
	9,5					500	3.000	3,5 - 5,0			01110004810
	11,0					500	3.000	5,0 - 6,5			01110004811
	13,0					250	2.000	6,5 - 8,0			01110004813
	14,5					250	2.000	8,0 - 9,5			01110004814
	16,0					250	2.000	9,5 - 11,0			01110004816
	18,0					250	1.500	11,0 - 13,0			01110004818
	21,0					250	1.500	13,0 - 16,0			01110004821
	25,0					200	1.200	16,0 - 20,0			01110004825
6,4	12,5	6,50	12,50	2,40	3,60	250	1.500	1,5 - 6,5	3600	4900	01110006412
	15,5					200	1.200	6,5 - 9,5			01110006415

d1 Ø m/m	L Nominalní m/m	OSTATNÍ BARVY		BALENÍ	
		Kód zboží		 vnitřní	 veknovní
3,2	6,5	01110	3206	500	4.000
	8,0	01110	3208	500	4.000
	9,5	01110	3209	500	4.000
	11,0	01110	3211	500	4.000
	12,5	01110	3212	500	4.000
4,0	8,0	01110	4008	500	4.000
	9,5	01110	4010	500	4.000
	11,0	01110	4011	500	4.000
	12,5	01110	4013	500	3.000
	14,5	01110	4014	500	3.000
4,8	8,5	01110	4808	500	3.000
	9,5	01110	4810	500	3.000
	11,0	01110	4811	500	3.000
	13,0	01110	4813	250	2.000
	14,5	01110	4814	250	2.000
	16,0	01110	4816	250	2.000
	18,0	01110	4818	250	1.500
	21,0	01110	4821	250	1.500
	25,0	01110	4825	200	1.200



TĚSNÍCÍ NÝTY

Zapuštěná hlava 120°

HLINÍK/OCEL



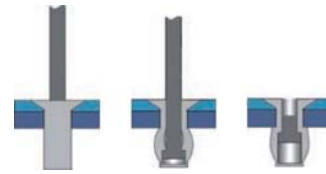
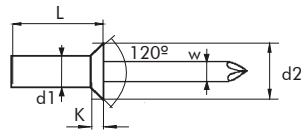

TĚLO: Hliník Al Mg 5

TRN: Lubrikovaná ocel



UNE - EN ISO 15974

Testováno dle EN ISO 14589

d1 Ø mm	L Nominální mm	 mm	d2 Ø mm	K mm	W Ø mm	BALENÍ		E mm		(N)	(N)	Kód zboží
						 vnitřní	 veškovní	MIN.	MÁX.			
4,8	10,0	4,90	9,50	1,80	2,65	500	3.000	4,5 - 6,0	2200	3100	01112004810	
	12,5					500	3.000	6,0 - 8,0			01112004813	
	14,5					250	2.000	8,0 - 10,0			01112004814	
	16,0					250	2.000	10,0 - 12,0			01112004816	
	22,0					250	1.500	13,0 - 18,0			01112004822	

TĚSNÍCÍ NÝTY

Velká hlava

HLINÍK/OCEL



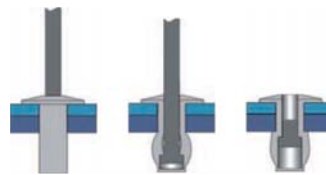
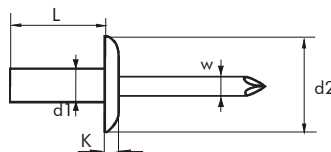

TĚLO: Hliník Al Mg 5

TRN: Lubrikovaná ocel



Testováno dle EN ISO 14589

d1 Ø mm	L Nominální mm	 mm	d2 Ø mm	K mm	W Ø mm	BALENÍ		E mm		(N)	(N)	Kód zboží
						 vnitřní	 veškovní	MIN.	MÁX.			
4,8	13,0	4,90	14,00	1,80	2,65	250	1.500	6,5 - 8,0	2200	3100	01120004813	
	18,0					200	1.200	11,0 - 13,0			01120004818	

HLINÍK/NEREZOVÁ OCEL

TĚSNÍCÍ NÍTY Plochá hlava

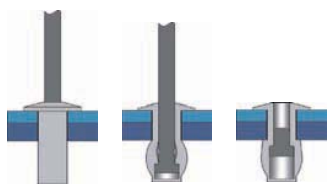





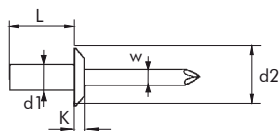

TĚLO: Hliník Al Mg 5

TRN: Nerezová ocel A2/304



Testováno dle EN ISO 14589

d1 Ø mm	L Nominální mm		d2 Ø mm	K mm	W Ø mm	BALENÍ					Kód zboží
						 vnitřní	 veknovní				
3,2	6,5	3,30	6,40	1,00	1,70	500	4.000	0,5 - 2,0	1100	1450	01119003207
	8,0					500	4.000	2,0 - 3,5			01119003208
	9,5					500	4.000	3,5 - 5,0			01119003209
	12,5					500	4.000	6,5 - 8,0			01119003212
4,0	8,0	4,10	7,90	1,40	2,20	500	4.000	0,5 - 3,5	1600	2200	01119004008
	9,5					500	4.000	3,5 - 5,0			01119004010
	11,0					500	4.000	5,0 - 6,5			01119004011
	12,5					500	3.000	6,5 - 8,0			01119004013
4,8	8,0	4,90	9,30	1,70	2,65	500	3.000	0,5 - 3,5	2200	3100	01119004808
	9,5					500	3.000	3,5 - 5,0			01119004810
	11,0					500	3.000	5,0 - 6,5			01119004811
	13,0					250	2.000	6,5 - 8,0			01119004813
	14,5					250	2.000	8,0 - 9,5			01119004814
	16,0					250	2.000	9,5 - 11,0			01119004816
	18,0					250	1.500	11,0 - 13,0			01119004818
	21,0					250	1.500	13,0 - 16,0			01119004821
25,0					200	1.200	16,0 - 20,0			01119004825	

Pozn: Na dotaz umíme nabídnout výrobu dalších rozměrů a lakování dle RAL.

HLINÍK/HLINÍK

TĚSNÍCÍ NÍTY Plochá hlava

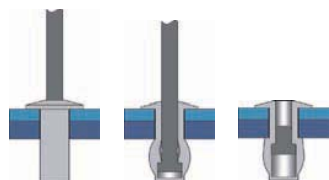





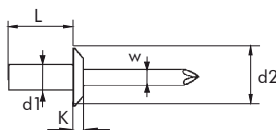

TĚLO: Hliník

TRN: Hliník



UNE - EN ISO 15975

Testováno dle EN ISO 14589

d1 Ø mm	L Nominální mm		d2 Ø mm	K mm	W Ø mm	BALENÍ					Kód zboží
						 vnitřní	 veknovní				
3,2	8,0	3,30	6,40	1,00	1,80	500	4.000	0,5 - 2,0	460	540	01190003208
	9,5					500	4.000	2,0 - 5,0			01190003209
	11,0					500	4.000	5,0 - 6,5			01190003211
4,0	9,5	4,10	7,90	1,40	2,20	500	4.000	3,5 - 5,0	720	760	01190004009
	12,5					500	3.000	5,0 - 8,0			01190004012
4,8	9,5	4,90	9,30	1,70	2,65	500	3.000	3,5 - 5,0	1000	1400	01190004809
	11,5					500	3.000	5,0 - 6,5			01190004811
	12,5					250	2.000	6,5 - 8,0			01190004812
	14,5					250	2.000	8,0 - 9,5			01190004814
	18,0					250	1.500	9,5 - 13,0			01190004818

PROFILOVANÉ NÝTY

Speciálně navržený nýt s dodatečnou přidanou hodnotou v aplikaci
Pro aplikace v automobilovém průmyslu a kovovýrobě
Rychlé a jednoduché řešení snižující montážní náklady







PROFILOVANÉ NÝTY

HLINÍK/OCEL

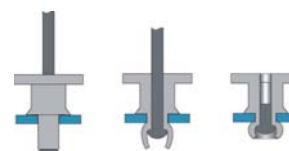
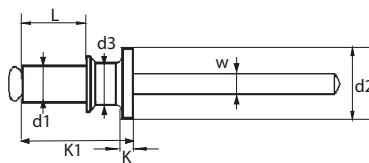

TĚLO: Hliník Al Mg 3,5
TRN: Pozinkovaná ocel A1K









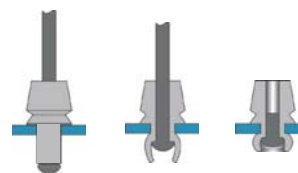
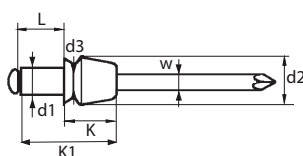

d1 Ø mm	L Nominalní mm		d2 Ø mm	d3 Ø mm	K1 mm	K mm	W Ø mm	BALENÍ					Kód zboží	
		mm						vnitřní	veškovní	MIN. E mm MÁX.	(N)	(N)		
2,4	5,0		2,50	5,00	3,00	8,50	1,00	1,45	1.000	8.000	3,0	340	490	01900002405



TĚLO: Hliník Al Mg 3,5
TRN: Pozinkovaná ocel A1K



d1 Ø mm	L Nominalní mm		d2 Ø mm	d3 Ø mm	K1 mm	K mm	W Ø mm	BALENÍ					Kód zboží	
		mm						vnitřní	veškovní	MIN. E mm MÁX.	(N)	(N)		
3,0	5,0		3,10	4,30	3,60	11,00	6,00	1,80	500	4.000	3,0	350	500	01900003005

d1 Ø mm	L Nominalní mm		d2 Ø mm	d3 Ø mm	K1 mm	K mm	W Ø mm	BALENÍ					Kód zboží	
		mm						vnitřní	veškovní	MIN. E mm MÁX.	(N)	(N)		
3,9	7,5		4,10	6,50	3,60	13,50	5,90	2,10	500	3.000	5,0	1700	2000	019000039076

ZATLOUKACÍ NÝT

Ideální pro spojení kovů se dřevem, cihlou či betonem.

Možnost použití pro slepé díry (neprůchozí).
Velká hlava poskytuje širokou dosedací plochu.
Odolný vůči korozi.



VYUŽITÍ VE STAVEBNICTVÍ

Tento typ nýtu má široké využití ve stavebnictví k upevnění různých plechů, parapetů, listů, nároží, izolací atd.

Jednoduchá aplikace se provádí úderem kladivem do nerezového trnu, který roztáhne hliníkové tělo nýtu do třech částí, které zajišťují ukotvení v materiálu (cihla, beton, dřevo...). Nýty nevyžadují průchozí otvor.





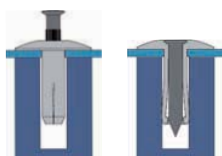

HLINÍK/NEREZOVÁ OCEL

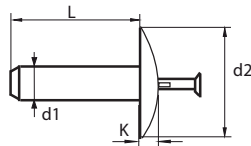
NÝTY DO BETONU Velká hlava



TĚLO: Hliník Al Mg 3
TRN: Nerezová ocel A2/304



d1 Ø mm	L Nominální mm	 mm	d2 Ø mm	W Ø mm	BALENÍ		 E mm MIN. MAX.	 (N)	 (N)	Kód zboží	
					 vnitřní	 veškovní					
4,8	7,6	5,0(+0,2)	16,00	1,50			3.000	2,9 - 4,4	3500	1900	G1509004808
	10,2						3.000	4,4 - 7,0	G1509004810		
	12,7					3.000	7,0 - 9,5	G1509004813			
	15,3					3.000	9,5 - 12,1	G1509004815			
	17,8					2.500	12,1 - 14,6	G1509004818			
	20,3					2.000	14,6 - 17,1	G1509004820			
	22,9					2.000	17,1 - 19,7	G1509004823			
	25,4					2.000	19,7 - 22,2	G1509004825			
	27,9					2.000	22,2 - 24,8	G1509004828			
	30,4					1.500	24,8 - 26,5	G1509004830			
	35,0					1.500	29,1 - 31,5	G1509004835			
	40,0					1.000	34,1 - 36,5	G1509004840			
	50,0					1.000	44,2 - 46,5	G1509004850			

OCELOVÉ NÝTY

Pro maximální ochranu vůči korozi našich ocelových nýtů využíváme různých povrchových úprav od zinkování až po organické povrchové úpravy.



POVRCHOVÉ ÚPRAVY OCELOVÝCH NÝTŮ

BRALO nabízí různé povrchové úpravy. Maximální odolnosti vůči korozi ocelových trhacích nýtů a nýťovacích matic lze dosáhnout použitím speciální impregnace (transparentní nebo černá).

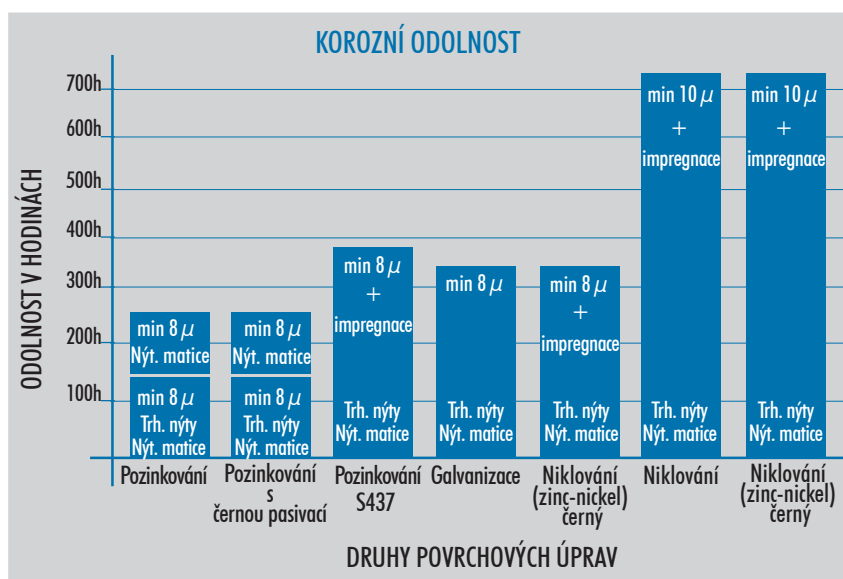

Všechny druhy pozinkování dle normy EN ISO 4042

PŘÍKLADY NEJČASTĚJŠÍCH POVRCHOVÝCH ÚPRAV



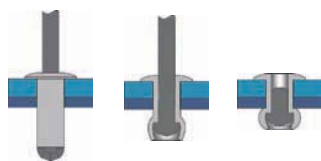



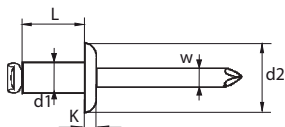

TĚLO: Pozinkovaná ocel A3K

TRN: Pozinkovaná ocel A1K



UNE - EN ISO 15979

Testováno dle EN ISO 14589

d1 Ø mm	L Nominální mm	 mm	d2 Ø mm	K mm	W Ø mm	BALENÍ		E mm		 (N)	 (N)	Kód zboží
						 vnitřní	 veškovní	MIN.	MAX.			
3,0	6	3,10	6,00	1,00	2,00	500	4.000	0,5 - 3,0	950	1100	01210003006	
	8					500	4.000	3,0 - 5,0			01210003008	
	10					500	4.000	5,0 - 6,5			01210003010	
	12					500	4.000	6,5 - 8,0			01210003012	
3,2	6	3,30	6,40	1,00	2,00	500	4.000	0,5 - 3,0	1100	1200	01210003206	
	8					500	4.000	3,0 - 5,0			01210003208	
	10					500	4.000	5,0 - 6,5			01210003210	
	12					500	4.000	6,5 - 8,0			01210003212	
	14					500	4.000	8,0 - 10,0			01210003214	
	16					500	3.000	10,0 - 12,0			01210003216	
4,0	6	4,10	8,00	1,30	2,40	500	4.000	1,0 - 3,0	1700	2200	01210004006	
	8					500	4.000	3,0 - 5,0			01210004008	
	10					500	4.000	5,0 - 6,5			01210004010	
	12					500	3.000	6,5 - 9,0			01210004012	
	14					500	3.000	9,0 - 10,0			01210004014	
	16					500	3.000	10,0 - 12,0			01210004016	
	18					500	3.000	12,0 - 14,0			01210004018	
	20					500	3.000	14,0 - 16,0			01210004020	
4,8	6	4,90	9,50	1,40	2,93	500	3.000	1,0 - 3,0	2900	3100	01210004806	
	8					500	3.000	2,5 - 4,0			01210004808	
	10					500	3.000	4,0 - 6,0			01210004810	
	12					250	2.000	6,0 - 8,0			01210004812	
	14					250	2.000	8,0 - 9,5			01210004814	
	16					250	2.000	9,5 - 11,0			01210004816	
	18					250	1.500	10,0 - 13,0			01210004818	
	21					250	1.500	11,0 - 15,0			01210004821	
	24					200	1.200	15,0 - 19,5			01210004824	
	30					200	1.200	19,5 - 25,0			01210004830	
	35					150	900	25,0 - 30,0			01210004835	
	5,0	8	5,10	9,50	1,60	2,93	500	3.000	2,5 - 4,0	3100	4000	01210005008
10						500	3.000	4,0 - 6,0			01210005010	
12						250	2.000	6,0 - 8,0			01210005012	
14						250	2.000	8,0 - 9,5			01210005014	
16						250	2.000	9,5 - 11,0			01210005016	
18						250	1.500	10,0 - 13,0			01210005018	
20						250	1.500	11,0 - 15,0			01210005020	
25						200	1.200	15,0 - 19,5			01210005025	
30						200	1.200	19,5 - 25,0			01210005030	
35						150	900	25,0 - 30,0			01210005035	
40						150	900	30,0 - 34,0			01210005040	
45						100	600	34,0 - 39,0			01210005045	
50						100	600	39,0 - 44,0			01210005050	
60						100	600	49,0 - 54,0			01210005060	
65					100	600	54,0 - 59,0			01210005065		
6,0	8	6,10	12,00	1,80	3,60	250	1.500	1,5 - 3,0	4300	4800	01210006008	
	10					250	1.500	3,0 - 4,0			01210006010	
	12					250	1.500	4,0 - 6,0			01210006012	
	14					250	1.500	6,0 - 8,0			01210006014	
	16					200	1.200	8,0 - 10,0			01210006016	
	18					200	1.200	10,0 - 12,0			01210006018	
	20					200	1.200	12,0 - 14,0			01210006020	
	25					150	900	14,0 - 19,0			01210006025	
	30					150	900	19,0 - 24,0			01210006030	
6,4	8	6,50	13,00	2,20	3,85	250	1.500	1,5 - 3,0	4900	5700	01210006408	
	10					250	1.500	3,0 - 4,0			01210006410	
	12					250	1.500	4,0 - 6,0			01210006412	
	15					200	1.200	6,0 - 9,0			01210006415	
	18					200	1.200	9,0 - 11,0			01210006418	
	20					150	900	9,0 - 13,0			01210006420	
	22					150	900	13,0 - 16,0			01210006422	
	25					150	900	13,0 - 19,0			01210006425	
	30					100	600	19,0 - 24,0			01210006430	
	35					100	600	24,0 - 29,0			01210006435	

STANDARDNÍ NÝTY

Zapuštěná hlava 120°

OCEL/OCEL





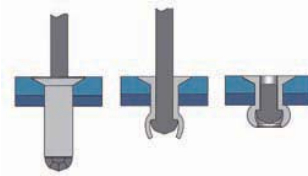
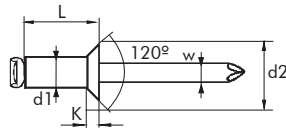

TĚLO: Pozinkovaná ocel A3K

TRN: Pozinkovaná ocel A1K



UNE - EN ISO 15980

Testováno dle EN ISO 14589

d1 Ø mm	L Nominální mm	 mm	d2 Ø mm	K mm	W Ø mm	BALENÍ		 E mm MIN. MÁX.	 (N)	 (N)	Kód zboží
						 vnější	 vnitřní				
3,2	6	3,30	6,30	1,00	2,00	500	4.000	1,5 - 3,5	1100	1200	01220003206
	8					500	4.000	3,5 - 5,5			01220003208
	10					500	4.000	5,5 - 7,0			01220003210
	12					500	4.000	7,0 - 9,0			01220003212
4,0	6	4,10	7,60	1,30	2,40	500	4.000	2,0 - 3,0	1700	2200	01220004006
	8					500	4.000	3,0 - 5,0			01220004008
	10					500	4.000	5,0 - 6,5			01220004010
	12					500	3.000	6,5 - 8,0			01220004012
	14					500	3.000	8,0 - 10,0			01220004014
4,8	8	4,90	9,50	1,40	2,93	500	3.000	2,5 - 4,0	2900	3100	01220004808
	10					500	3.000	4,0 - 6,0			01220004810
	12					250	2.000	6,0 - 8,0			01220004812
	14					250	2.000	8,0 - 10,0			01220004814
	16					250	2.000	10,0 - 11,0			01220004816
	18					250	1.500	11,0 - 13,0			01220004818
	20					250	1.500	13,0 - 15,0			01220004820
5,0	12	5,10	9,50	1,60	2,93	250	2.000	6,0 - 8,0	2900	3100	01220005012
	25					200	1.200	15,0 - 19,5			01220005025
6,4	10	6,50	12,50	2,00	3,85	250	1.500	3,0 - 4,0	4900	5700	01220006410
	13					250	1.500	5,0 - 7,0			01220006413
	16					250	1.500	8,0 - 10,0			01220006416
	28					150	900	17,0 - 22,0			01220006428

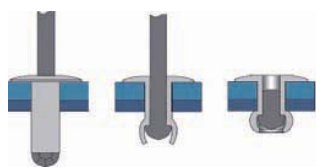

TĚLO: Pozinkovaná ocel A3K

TRN: Pozinkovaná ocel A1K

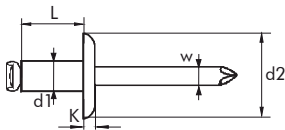

Testováno dle EN ISO 14589

d1 Ø mm	L Nominalní mm	 mm	d2 Ø mm	K mm	W Ø mm	BALENÍ		E mm		(N)	(N)	Kód zboží
						vnitřní	veškovní	MIN.	MÁX.			
4,0	6	4,10	10,00	1,50	2,40	500	3.000	1,0 - 3,0	1700	2200		01230004006
	8					500	3.000	3,0 - 5,0				01230004008
	10					500	3.000	5,0 - 6,5				01230004010
	12					500	3.000	6,5 - 9,0				01230004012
	14					500	3.000	9,0 - 10,0				01230004014
4,8	10	4,90	14,00	2,10	2,93	250	1.500	4,0 - 6,0	2900	3100		01230004810
	12					250	1.500	6,0 - 8,0				01230004812
	14					250	1.500	8,0 - 9,5				01230004814
	16					250	1.500	9,5 - 11,0				01230004816
	18					200	1.200	10,0 - 13,0				01230004818
	21					200	1.200	11,0 - 15,0				01230004821
	24					150	900	15,0 - 20,0				01230004824
	30					150	900	20,0 - 25,0				01230004830
	35					100	600	25,0 - 30,0				01230004835
	4,8	10				4,90	16,00	2,10				2,93
12			250	1.500	6,0 - 8,0	01240004812						
14			200	1.200	8,0 - 9,5	01240004814						
16			200	1.200	9,5 - 11,0	01240004816						
18			200	1.200	10,0 - 13,0	01240004818						
21			150	900	11,0 - 15,0	01240004821						
24			150	900	15,0 - 19,5	01240004824						
6,4	12	6,50	19,00	3,00	3,90		1.000	4,0 - 6,0	4900	5700		G1240006412
	15						1.000	6,0 - 9,0				G1240006415
	18						1.000	9,0 - 12,0				G1240006418
	30						500	19,0 - 24,0				G1240006430

VÍCESVĚRNÉ NÝTY MULTIGRIP

Plochá hlava

OCEL/OCEL





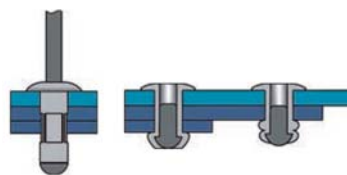
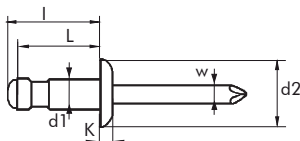

TĚLO: Pozinkovaná ocel A3K

TRN: Pozinkovaná ocel A1K



Testováno dle EN ISO 14589

d1 Ø mm	L Nominalní mm	 mm	d2 Ø mm	K mm	W Ø mm	BALENÍ		l Max. mm	E mm		 (N)	 (N)	Kód zboží
						 vnitřní	 veknovní		MIN.	MÁX.			
3,2	9,0	3,40	6,50	1,00	2,00	500	4.000	11,3	2,0 - 5,0	1400	1900	01280003209	
	13,0					500	4.000	15,3	4,0 - 6,0			01280003213	
4,0	11,0	4,10	8,00	1,40	2,75	500	3.000	14,5	2,0 - 5,0	1900	2500	01280004011	
4,8	10,5	4,90	9,50	1,80	2,93	250	2.000	13,0	1,0 - 4,5	2000	3300	01280004810	
	13,0					250	2.000	16,0	4,0 - 6,5			01280004813	

BRALO Vícesvěrné nýty Multigrip zajišťují homogenní upevnění, pevný a vysoce kvalitní spoj. Disponují širokým svěrným rozsahem. Při správné aplikaci je odolný vůči povětrnostním podmínkám, což z něj dělá adekvátní alternativu k těsnicímu nýtu.

SLUPKOVÉ NÝTY

Plochá hlava

OCEL/OCEL





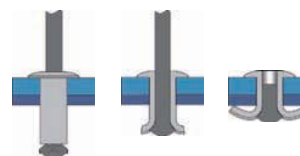
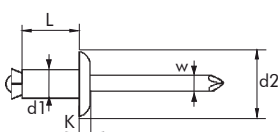

TĚLO: Pozinkovaná ocel A3K

TRN: Pozinkovaná ocel A1K



Testováno dle EN ISO 14589

d1 Ø mm	L Nominalní mm	 mm	d2 Ø mm	K mm	W Ø mm	BALENÍ		l Max. mm	E mm		 (N)	 (N)	Kód zboží
						 vnitřní	 veknovní		MIN.	MÁX.			
4,2	9,0	4,30-4,40	7,80	1,20	2,45		3.000	5,0	1000	1200	G1850004009		

OCEL/OCEL

VÍCESVĚRNÝ HARDVEX

Velká hlava

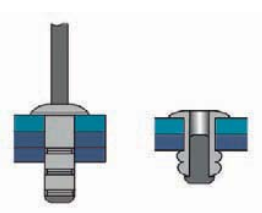





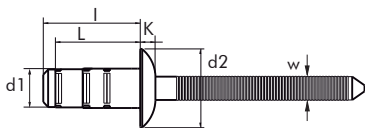







TĚLO: Pozinkovaná ocel A3K

TRN: Pozinkovaná ocel A1K



Testováno dle EN ISO 14589

d1 Ø mm	L Nominální mm	 mm	d2 Ø mm	K mm	W Ø mm	BALENÍ		I Max. mm	 E mm	 (N)	 (N)	Kód zboží			
						 vnitřní	 veknovní								
4,8	11,0	4,90	9,80	1,50	3,00			14,00	 1,5 - 6,5	 3000	 3100	G1874004811			
	14,5											2.000	17,50	1,5 - 9,0	G1874004814
	17,5											1.500	20,50	6,5 - 12,5	G1874004817
6,4	14,0	6,60	13,00	2,50	3,95			16,80	1,5 - 7,6	3100	3600	G1874006414			

Pozn: Tato řada je vyráběná na základě poptávky. Pro informace ohledně minimálního množství a dodacích termínů nás prosím kontaktujte.

OCEL/OCEL

VÍCESVĚRNÝ HARDVEX

Velká hlava

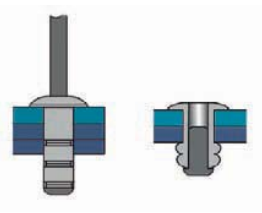





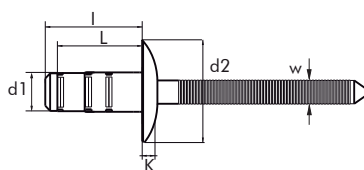





TĚLO: Pozinkovaná ocel A3K

TRN: Pozinkovaná ocel A1K



Testováno dle EN ISO 14589

d1 Ø mm	L Nominální mm	 mm	d2 Ø mm	K mm	W Ø mm	BALENÍ		I Max. mm	 E mm	 (N)	 (N)	Kód zboží			
						 vnitřní	 veknovní								
4,8	11,0	4,90	16,00	2,00	3,00			14,0	 1,5 - 6,5	 3000	 3300	G1877004811			
	14,5											1.000	17,5	1,5 - 9,0	G1877004814
	17,5											20,5	6,5 - 12,5	G1877004817	

Pozn: Tato řada je vyráběná na základě poptávky. Pro informace ohledně minimálního množství a dodacích termínů nás prosím kontaktujte.

TĚSNÍCÍ NÝTY

Plochá hlava

OCEL/OCEL







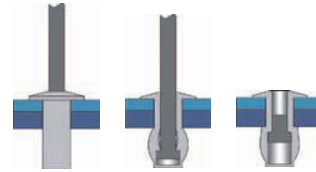
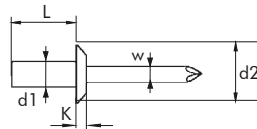

TĚLO: Pozinkovaná ocel A3K

TRN: Pozinkovaná ocel A3K



UNE - EN ISO 15976

Testováno dle EN ISO 14589

d1 Ø mm	L Nominální mm	 mm	d2 Ø mm	K mm	W Ø mm	BALENÍ		 E mm MIN. MÁX.	 (N)	 (N)	Kód zboží
						 vnitřní	 veknovní				
3,2	6,0	3,30	6,50	1,00	1,90	500	4.000	0,5 - 1,5	1150	1300	01290003206
	8,0					500	4.000	1,5 - 3,0			01290003208
	9,5					500	4.000	3,0 - 5,0			01290003209
	12,0					500	4.000	5,0 - 6,5			01290003212
4,0	8,0	4,10	8,20	1,40	2,30	500	4.000	1,5 - 3,0	1700	1550	01290004008
	10,0					500	4.000	3,0 - 5,0			01290004010
	12,0					500	3.000	5,0 - 6,5			01290004012
	15,0					500	3.000	6,5 - 10,5			01290004015
4,8	9,5	4,90	9,80	1,70	2,90	500	3.000	1,0 - 4,0	2400	2800	01290004809
	12,0					500	3.000	4,0 - 5,0			01290004812

GRIPMATE NÝTY

Plochá hlava

OCEL/OCEL







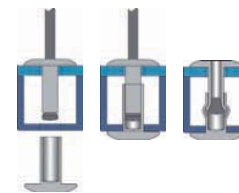
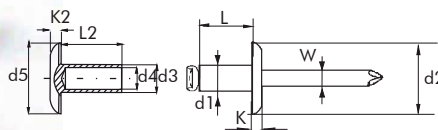



TĚLO: Pozinkovaná ocel A3K

TRN: Pozinkovaná ocel A1K



Testováno dle EN ISO 14589

d1 Ø mm	L Nominální mm	 mm	d2 Ø mm	K mm	W Ø mm	BALENÍ		 E mm MIN. MÁX.	Kód zboží
						 vnitřní	 veknovní		
4,7	11,5	4,90	16,00	2,50	2,93	1.500	1.500	14,0 - 18,0	G1234004811
	14,5					1.500	1.500	19,0 22,0	G1234004814

d1 Ø mm	L2 Nominální mm	 mm	k2 mm	d3 Ø mm	d4 Ø mm	d5 Ø mm	BALENÍ		 E mm MIN. MÁX.	Kód zboží
							 vnitřní	 veknovní		
6,3	14,5	7,80	2,50	6,30	5,00	16,00	1.500	14,0 - 18,0	G12340063145	

Pozn: Gripmate nýty se prodávají zvlášť

Nerezové trhací nýty

Nerezová ocel má vysokou korozní odolnost a používá se pro aplikace v náročném a agresivním prostředí.

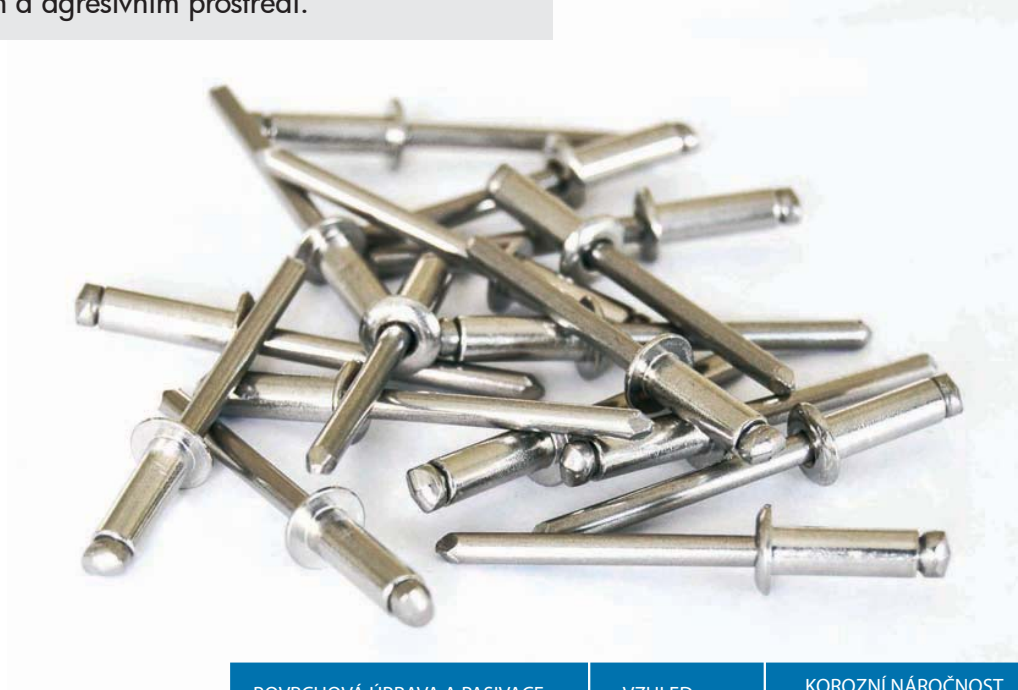

POVRCHOVÁ ÚPRAVA A PASIVACE	VZHLED	KOROZNÍ NÁROČNOST PROSTŘEDÍ
Nerezová ocel s pasivací	Nezměněn	Velice náročné

TEPLOTA

BRALO nabízí různé druhy nerezových materiálů, nerezová ocel A2 (AISI 304) a nerezová ocel A4 (AISI 316).

Pro nejvyšší odolnost doporučujeme výběr materiálu na základě materiálů spojovaných dílů.

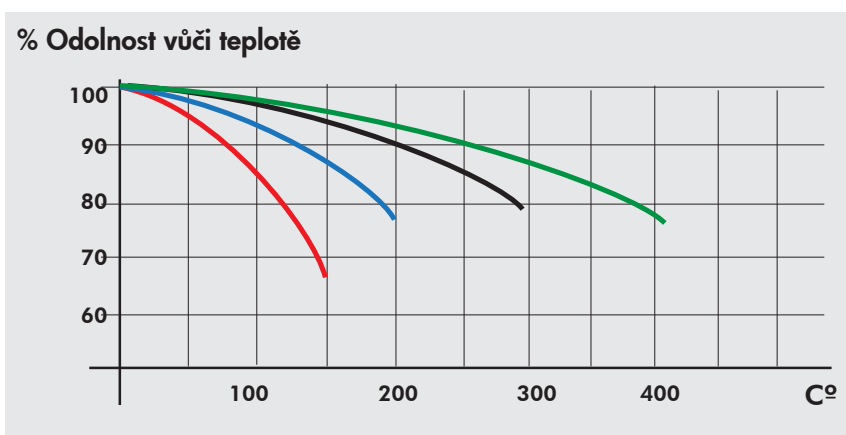

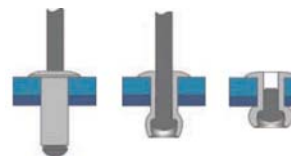
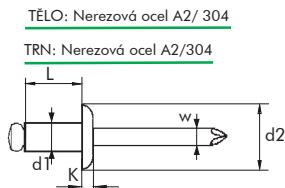

Hliník ———
Niklovaná ocel ———
Pozinkovaná ocel ———
Nerezová ocel ———

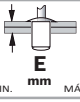

UNE - EN ISO 15983

Testováno dle EN ISO 14589

d1 Ø mm	L Nominalní mm		d2 Ø mm	K mm	W Ø mm	BALENÍ					Kód zboží
						vnitřní	veškovní				
2,4	6	2,50	5,00	0,60	1,50	1.000	8.000	2,0 - 3,5	1000	1250	01260002406
	8					1.000	8.000	3,5 - 5,5			01260002408
	10					1.000	8.000	5,5 - 7,5			01260002410
	12					500	4.000	7,5 - 9,5			01260002412
3,0	5	3,10	6,00	1,00	2,00	500	4.000	0,5 - 2,5	1800	2200	01260003005
	6					500	4.000	0,5 - 3,0			01260003006
	8					500	4.000	3,0 - 5,0			01260003008
	10					500	4.000	5,0 - 6,5			01260003010
	12					500	4.000	6,5 - 8,5			01260003012
	14					500	4.000	8,5 - 10,5			01260003014
3,2	6	3,30	6,40	1,00	2,10	500	4.000	0,5 - 3,0	1900	2500	01260003206
	8					500	4.000	3,0 - 5,0			01260003208
	10					500	4.000	5,0 - 6,5			01260003210
	12					500	4.000	6,5 - 8,5			01260003212
	15					500	4.000	8,5 - 12,0			01260003215
	18					500	3.000	12,0 - 15,0			01260003218
4,0	6	4,10	8,00	1,30	2,40	500	4.000	1,0 - 2,5	2700	3500	01260004006
	8					500	4.000	2,5 - 4,5			01260004008
	10					500	4.000	4,5 - 6,5			01260004010
	12					500	3.000	6,5 - 8,5			01260004012
	14					500	3.000	8,5 - 10,0			01260004014
	16					500	3.000	10,0 - 12,0			01260004016
	18					500	3.000	12,0 - 14,0			01260004018
	20					500	3.000	14,0 - 16,0			01260004020
	25					250	2.000	16,0 - 20,0			01260004025
	4,8	8	4,90	9,00	1,60	3,10	500	3.000	2,0 - 4,0	4000	5000
10						500	3.000	4,0 - 6,0			01260004810
12						250	2.000	6,0 - 8,0			01260004812
14						250	2.000	8,0 - 9,5			01260004814
16						250	2.000	9,5 - 11,0			01260004816
18						250	1.500	11,0 - 13,0			01260004818
20						250	1.500	13,0 - 16,0			01260004820
25						200	1.200	16,0 - 19,0			01260004825
30						200	1.200	19,0 - 24,0			01260004830
35						150	900	24,0 - 29,0			01260004835
40						150	900	29,0 - 34,0			01260004840
5,0		8	5,10	9,00	1,60	3,10	500	3.000	2,0 - 4,0	4700	5800
	10					500	3.000	4,0 - 6,0			01260005010
	12					250	2.000	6,0 - 8,0			01260005012
	14					250	2.000	8,0 - 9,5			01260005014
	16					250	2.000	9,5 - 11,0			01260005016
	20					250	1.500	13,0 - 16,0			01260005020
	25					200	1.200	16,0 - 19,0			01260005025
	30					200	1.200	19,0 - 24,0			01260005030
	35					150	900	24,0 - 29,0			01260005035
	40					150	900	29,0 - 34,0			01260005040
6,4	12	6,50	12,50	2,20	3,85	250	1.500	2,0 - 6,0	7000	9000	01260006412
	15					250	1.500	6,0 - 9,0			01260006415
	18					200	1.200	9,0 - 12,0			01260006418
	20					150	900	12,0 - 14,0			01260006420
	25					150	900	14,0 - 18,0			01260006425

Pozn: Tato řada nýtů je na dotaz dostupná v mnoha barevných provedeních.

NEREZOVÁ OCEL A2/NEREZOVÁ OCEL A2

STANDARDNÍ NÝTY
Zapuštěná hlava 120°

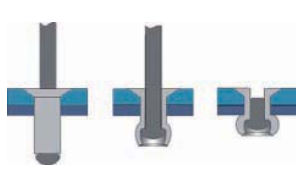





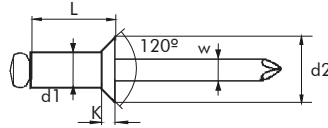

TĚLO: Nerezová ocel A2/304

TRN: Nerezová ocel A2/304



UNE - EN ISO 15984

Testováno dle EN ISO 14589

d1 Ø mm	L Nominalní mm		d2 Ø mm	K mm	W Ø mm	BALENÍ		 E mm			Kód zboží
						 vnitřní	 veknovní				
3,2	6	3,30	6,30	1,00	2,10	500	4.000	1,5 - 3,0	1900	2500	01270003206
	8					500	4.000	3,0 - 5,5			01270003208
	10					500	4.000	5,5 - 6,5			01270003210
	12					500	4.000	6,5 - 8,5			01270003212
4,0	8	4,10	7,60	1,30	2,40	500	4.000	2,5 - 4,5	2700	3500	01270004008
	10					500	4.000	4,5 - 6,5			01270004010
	12					500	3.000	6,5 - 8,5			01270004012
	14					500	3.000	8,5 - 10,0			01270004014
4,8	8	4,90	9,50	1,40	3,10	500	3.000	2,5 - 4,0	4000	5000	01270004808
	10					500	3.000	4,0 - 6,0			01270004810
	12					250	2.000	6,0 - 8,0			01270004812
	14					250	2.000	8,0 - 10,0			01270004814
	18					250	1.500	12,0 - 14,0			01270004818

NEREZOVÁ OCEL A2/NEREZOVÁ OCEL A2

STANDARDNÍ NÝTY
Velká hlava

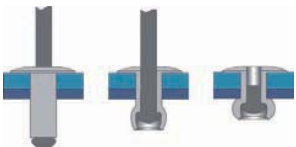





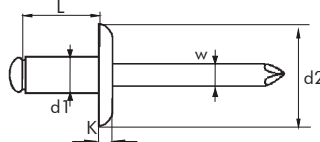

TĚLO: Nerezová ocel A2/304

TRN: Nerezová ocel A2/304



Testováno dle EN ISO 14589

d1 Ø mm	L Nominalní mm		d2 Ø mm	K mm	W Ø mm	BALENÍ		 E mm			Kód zboží
						 vnitřní	 veknovní				
3,2	10	3,30	9,50	1,40	2,10	500	4.000	5,0 - 6,5	1900	2500	01310003210
4,0	10	4,10	12,00	1,80	2,40	500	3.000	4,5 - 6,5	2700	3500	01310004010
	13					250	2.000	6,5 - 9,5			01310004013
	16					250	2.000	9,5 - 12,0			01310004016
4,8	8	4,90	14,00	2,20	3,10	250	1.500	1,5 - 3,0	4000	5000	01311004808
4,8	8	4,90	16,00	2,20	3,10	250	1.500	2,0 - 4,0	4000	5000	01310004808
	10					250	1.500	4,0 - 6,0			01310004810
	12					250	1.500	6,0 - 8,0			01310004812
	14					250	1.500	8,0 - 10,0			01310004814
	16					200	1.200	9,5 - 11,0			01310004816
	18					150	900	11,0 - 13,0			01310004818
	20					150	900	13,0 - 16,0			01310004820
	22					100	600	16,0 - 18,0			01310004822
	25					100	600	16,0 - 19,0			01310004825
	30					100	600	19,0 - 24,0			01310004830
35					100	600	24,0 - 29,0			01310004835	

Pozn: Tato řada nýtů je na dotaz dostupná v mnoha barevných provedeních.

www.brало.cz

REMACHES - BLIND RIVETS - RIVETS - RIVETTI - RIBITES
TUERCAS REMACHABLES - INSERT NUTS - ECROUS À SERTIR - BLINDNIETMUTTERN - INSERTI - PORCAS DE RIBITAR

NEREZOVÁ OCEL A4/NEREZOVÁ OCEL A4

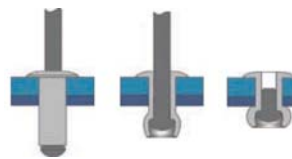
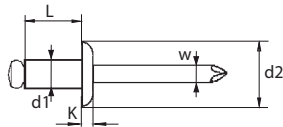

TĚLO: Nerezová ocel A4/316

TRN: Nerezová ocel A4/316



UNE - EN ISO 15983

Testováno dle EN ISO 14589

d1 Ø mm	L Nominalní mm	 mm	d2 Ø mm	K mm	W Ø mm	BALENÍ		 E mm	MIN. mm	MÁX. mm	Kód zboží
						vnitřní	veškovní				
3,2	6	3,30	6,40	1,00	2,10	500	4.000	0,5 - 3,0	1900	2500	01340003206
	8					500	4.000	3,0 - 5,0			01340003208
	10					500	4.000	5,0 - 6,5			01340003210
	12					500	4.000	6,5 - 8,5			01340003212
	15					500	4.000	8,5 - 12,0			01340003215
4,0	6	4,10	8,00	1,30	2,40	500	4.000	1,0 - 2,5	2700	3500	01340004006
	8					500	4.000	2,5 - 4,5			01340004008
	10					500	4.000	4,5 - 6,5			01340004010
	12					500	3.000	6,5 - 8,5			01340004012
	14					500	3.000	8,5 - 10,0			01340004014
	16					500	3.000	10,0 - 12,0			01340004016
	20					500	3.000	14,0 - 16,0			01340004020
4,8	8	4,90	9,00	1,60	3,10	500	3.000	2,0 - 4,0	4000	5000	01340004808
	10					500	3.000	4,0 - 6,0			01340004810
	12					250	2.000	6,0 - 8,0			01340004812
	14					250	2.000	8,0 - 9,5			01340004814
	16					250	2.000	9,5 - 11,0			01340004816
	18					250	1.500	11,0 - 13,0			01340004818
	20					250	1.500	13,0 - 16,0			01340004820
5,0	8	5,10	9,00	1,60	3,10	500	3.000	2,0 - 4,0	4700	5800	01340005008
	10					500	3.000	4,0 - 6,0			01340005010
	12					250	2.000	6,0 - 8,0			01340005012
	14					250	2.000	8,0 - 9,5			01340005014
	16					250	2.000	9,5 - 11,0			01340005016
	18					250	1.500	11,0 - 13,0			01340005018
	20					250	1.500	13,0 - 16,0			01340005020
	35					150	900	24,0 - 29,0			01340005035

NEREZOVÁ OCEL/NEREZOVÁ OCEL

TĚSNÍCÍ NÝTY
Plochá hlava

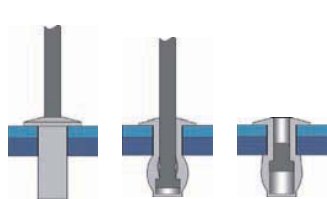





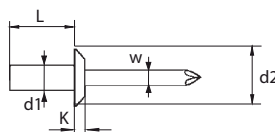

TĚLO: Nerezová ocel/304

TRN: Nerezová ocel/420



UNE - EN ISO 16585

Testováno dle EN ISO 14589

d1 Ø mm	L Nominalní mm	 mm	d2 Ø mm	K mm	W Ø mm	BALENÍ		 E mm	 (N)	 (N)	Kód zboží
						 vnitřní	 velkový				
3,2	8,0	3,30	6,50	1,00	1,90	500	4.000	1,5 - 3,0	2000	2200	01300003208
	9,5					500	4.000	1,5 - 4,5			01300003209
	12,0					500	4.000	5,0 - 6,5			01300003212
4,0	8,0	4,10	8,20	1,40	2,30	500	4.000	1,5 - 3,0	3000	3500	01300004008
	9,5					500	4.000	3,0 - 5,0			01300004009
	12,0					500	3.000	5,0 - 6,5			01300004012
	14,0					500	3.000	6,5 - 8,0			01300004014
	16,0					500	3.000	8,0 - 11,0			01300004016
4,8	9,5	4,90	9,80	1,70	2,90	500	3.000	1,0 - 4,0	4000	4400	01300004809
	12,0					500	3.000	4,0 - 6,0			01300004812
	13,0					250	2.000	5,0 - 7,0			01300004813
	15,0					250	2.000	5,0 - 9,0			01300004815
	16,0					250	2.000	6,0 - 10,0			01300004816
	17,0					250	2.000	10,0 - 12,0			01300004817
	18,0					250	1.500	11,0 - 13,0			01300004818
6,4	12,0	6,50	13,20	2,40	3,90	250	1.500	1,0 - 6,5	6000	8400	01300006412
	16,0					200	1.200	6,5 - 8,0			01300006416

Měděné trhací nýty

Tepelně a elektricky vodivé.

Použití ve stavebnictví.

Aplikace do měkkých materiálů.

Vysoká odolnost.



STANDARDNÍ NÝTY

Plochá hlava

MĚĎ/OCEL



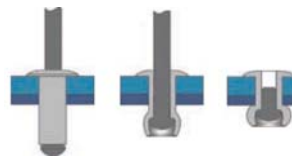
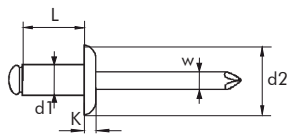

TĚLO: Měď

TRN: Pozinkovaná ocel A1K

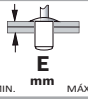

UNE - EN ISO 16582

Testováno dle EN ISO 14589

d1 Ø mm	L Nominální mm		d2 Ø mm	K mm	W Ø mm	BALENÍ					Kód zboží
						vnitřní	veškovní				
3,0	6	3,10	6,00	1,00	1,80	500	4.000	2,0 - 3,0	760	950	01250003006
	8					500	4.000	3,0 - 5,0			01250003008
	10					500	4.000	5,0 - 7,0			01250003010
	12					500	4.000	7,0 - 9,0			01250003012
4,0	6	4,10	8,00	1,30	2,40	500	4.000	2,5 - 3,5	1500	1800	01250004006
	8					500	4.000	3,5 - 5,0			01250004008
	10					500	4.000	5,0 - 7,0			01250004010
	12					500	3.000	7,0 - 8,5			01250004012
	14					500	3.000	8,5 - 10,0			01250004014
	16					500	3.000	10,0 - 12,5			01250004016
4,8	8	4,90	9,50	1,40	2,93	500	3.000	2,5 - 4,0	2000	2500	01250004808
	10					500	3.000	4,0 - 6,0			01250004810
	12					500	3.000	6,0 - 8,0			01250004812
	14					250	2.000	8,0 - 10,0			01250004814
	16					250	2.000	10,0 - 12,0			01250004816

STANDARDNÍ NÝTY

Plochá hlava

MĚĎ/BRONZ



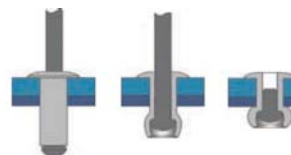
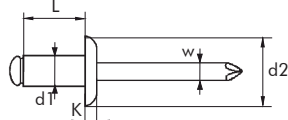

TĚLO: Měď

TRN: Bronz

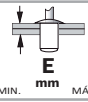

UNE - EN ISO 16582

Testováno dle EN ISO 14589

d1 Ø mm	L Nominální mm		d2 Ø mm	K mm	W Ø mm	BALENÍ					Kód zboží
						vnitřní	veškovní				
3,0	6	3,10	6,00	1,00	1,80	500	4.000	2,0 - 3,0	760	950	01400003006
	8					500	4.000	3,0 - 5,0			01400003008
	10					500	4.000	5,0 - 7,0			01400003010
	12					500	4.000	7,0 - 9,0			01400003012
3,2	6	3,30	6,40	1,00	2,00	500	4.000	2,0 - 3,0	800	1000	01400003206
	8					500	4.000	3,0 - 5,0			01400003208
	10					500	4.000	5,0 - 7,0			01400003210
	12					500	4.000	7,0 - 9,0			01400003212
4,0	6	4,10	8,00	1,30	2,40	500	4.000	2,5 - 3,5	1500	1800	01400004006
	8					500	4.000	3,5 - 5,0			01400004008
	10					500	4.000	5,0 - 7,0			01400004010
	12					500	3.000	7,0 - 8,5			01400004012
	14					500	3.000	8,5 - 10,0			01400004014
	16					500	3.000	10,0 - 12,5			01400004016

MĚĐ/OCEL

TĚSNICÍ NÝTY Plochá hlava

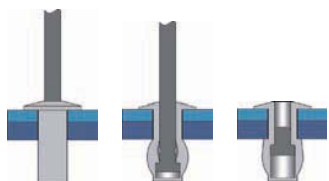

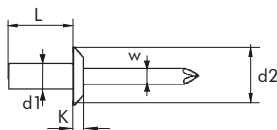

TĚLO: Měď

TRN: Lubrikovaná ocel

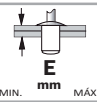

Testováno dle EN ISO 14589

d1 Ø mm	L Nominalní mm		d2 Ø mm	K mm	W Ø mm	BALENÍ					Kód zboží
						vnitřní	veškovní				
3,2	6,5	3,30	6,30	1,40	1,70	500	4.000	0,5 - 2,0	1250	1300	01320003206
	8,0					500	4.000	2,0 - 3,5			01320003208
	9,5					500	4.000	3,5 - 5,0			01320003209
	12,0					500	4.000	6,5 - 8,0			01320003212
4,0	8,0	4,10	8,00	1,40	2,20	500	4.000	0,5 - 3,5	2050	2900	01320004008
	10,0					500	4.000	3,0 - 5,0			01320004010
4,8	9,5	4,90	9,50	1,60	2,65	500	3.000	1,0 - 4,5	3350	3300	01320004809
	12,0					500	3.000	4,0 - 7,0			01320004812

MĚĐ/NEREZOVÁ OCEL

TĚSNICÍ NÝTY Plochá hlava

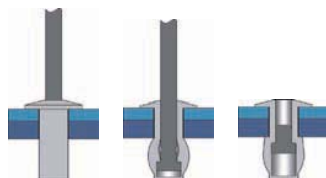

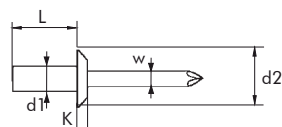

TĚLO: Měď

TRN: Nerezová ocel

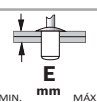
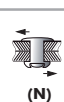

Testováno dle EN ISO 14589

d1 Ø mm	L Nominalní mm		d2 Ø mm	K mm	W Ø mm	BALENÍ					Kód zboží
						vnitřní	veškovní				
3,2	6,5	3,30	6,30	1,40	1,70	500	4.000	0,5 - 2,0	1250	2100	01329003206
	8,0					500	4.000	2,0 - 3,5			01329003208
	9,5					500	4.000	3,5 - 5,0			01329003209
4,0	8,0	4,10	8,00	1,40	2,20	500	4.000	0,5 - 3,5	1900	2500	01329004008
	10,0					500	4.000	3,5 - 5,0			01329004010

Pevnostní nýty: Structural, Hardlock, Hardgrip



PEVNOSTNÍ NÝT STRUCTURAL

Široký svěrný rozsah.
Vysoká odolnost na tahu i střihu.
Vodotěsné a tlakutěsné.
Vysoká tolerance pro velikost otvoru.

HARDGRIP NÝT

Ideální pro aplikace s tvrdými plasty a tenkými kovovými materiály.
Vytvořeny pro nejnáročnější aplikace vyžadující velkou sílu sevření.
Vysoká odolnost na tahu a střihu.
Naprosto vyplní otvor v aplikaci.

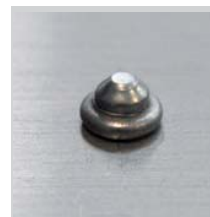

HARDLOCK NÝT

Určen pro díly vyžadující výjimečnou odolnost na tahu a střihu.
Účinný systém uzamčení hlavy díky vroubkům na trnu.
Obzvláště vhodný pro práci s tenkými kovovými materiály.
Vhodný pro použití v elektrotechnice.



Pevnostní nýty BRALO jsou navrženy tak, aby vyhovely nejnáročnějším požadavkům v aplikacích, u kterých je vyžadována nejvyšší odolnost na tahu a střihu. Použití je rychlé a jednoduché. Poskytují dlouhodobě neměnné vlastnosti v aplikaci. Značné využití mají tyto nýty v automobilovém průmyslu, stavebnictví, vzduchotechnice a systémech pro solární elektrárny.

PEVNOSTNÍ NÝTY BRALO

Pevnost střihu (N)

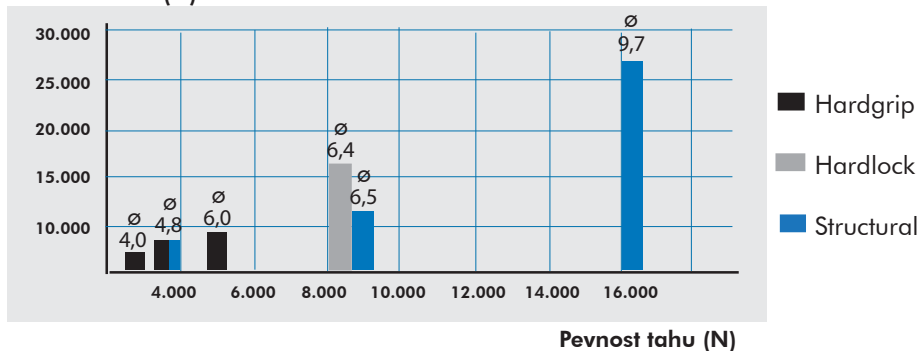

HLINÍK/HLINÍK

PEVNOSTNÍ NÝTY STRUCTURAL Plochá hlava

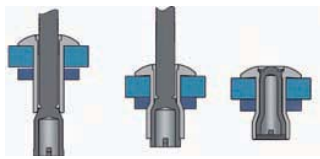





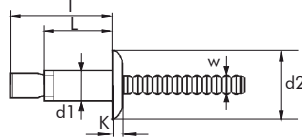



TĚLO: Hliník Al Mg 5

TRN: Hliník



Testováno dle EN ISO 14589

d1 Ø mm	L Nominální mm	 mm	d2 Ø mm	K mm	W Ø mm	BALENÍ		I Max. mm	E mm		 (N)	 (N)	Kód zboží
						 vnitřní	 veknovní		MIN.	MÁX.			
4,8	10,3	4,90-5,10	9,60	1,70	3,00	 vnitřní	 veknovní	18,5	1,5 - 6,8	2900	2550		G180100 4810 G180100 4813
	13,5								1,5 - 11,0				
6,5	14,0	6,60-7,00	13,00	2,50	4,00	 vnitřní	 veknovní	25,0	1,0 - 9,5	6000	4200		G180100 6514 G180100 6520
	20,0								2,0 - 16,0				



Pozn.: Tento nýt vyžaduje pro zanytování speciální násadku!
Pro další informace ke správné aplikaci nás prosím kontaktujte.

HLINÍK/HLINÍK

PEVNOSTNÍ NÝTY STRUCTURAL Zapuštěná hlava 100°

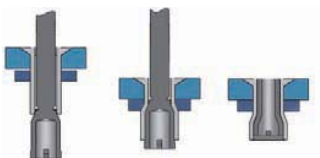





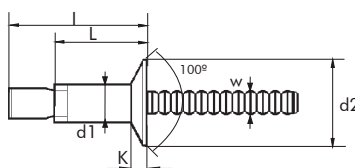

TĚLO: Hliník Al Mg 5

TRN: Hliník



Testováno dle EN ISO 14589

d1 Ø mm	L Nominální mm	 mm	d2 Ø mm	K mm	W Ø mm	BALENÍ		I Max. mm	E mm		 (N)	 (N)	Kód zboží
						 vnitřní	 veknovní		MIN.	MÁX.			
6,5	16,5	6,60-7,00	10,10	1,50	4,00	 vnitřní	 veknovní	26,5	3,2 - 12,0	6000	4200	G180200 6516	



Pozn.: Tento nýt vyžaduje pro zanytování speciální násadku!
Pro další informace ke správné aplikaci nás prosím kontaktujte.

PEVNOSTNÍ NÝTY STRUCTURAL

Plochá hlava

OCEL/OCEL







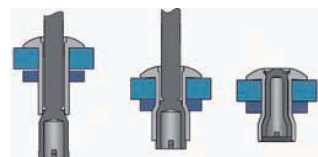
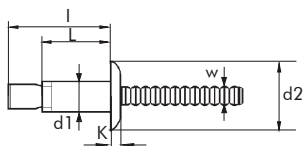

TĚLO: Pozinkovaná ocel A2K

TRN: Pozinkovaná ocel A2K



Testováno dle EN ISO 14589

d1 Ø mm	L Nominální mm	 mm	d2 Ø mm	K mm	W Ø mm	BALENÍ		I Max. mm	 E mm	 (N)	 (N)	Kód zboží				
						 vnitřní	 veškovní						MIN.	MÁX.		
4,8	10,3	4,90-5,10	9,70	1,80	3,00			18,5	1,5 - 6,8	5100	3900	G182100 4810				
	13,5													1,5 - 11,0	G182100 4813	
6,5	14,0	6,60-7,00	13,00	2,50	4,00			25,0	2,0 - 9,5	11200	8800	G182100 6514				
	20,0													35,0	2,0 - 16,0	G182100 6520
	22,0													37,0	6,0 - 18,0	G182100 6522
9,7	22,0	9,90-10,4	20,00	3,70	5,90			36,2	3,0 - 15,5	26300	17500	G182100 9722				



Pozn.: Tento nýt vyžaduje pro zanátyování speciální násadku!
Pro další informace ke správné aplikaci nás prosím kontaktujte.

PEVNOSTNÍ NÝTY STRUCTURAL

Zapuštěná hlava 100°

OCEL/OCEL







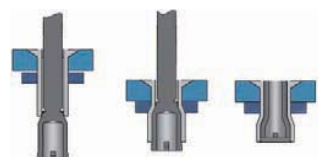
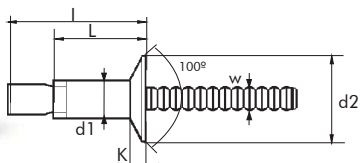

TĚLO: Pozinkovaná ocel A2K

TRN: Pozinkovaná ocel A2K



Testováno dle EN ISO 14589

d1 Ø mm	L Nominální mm	 mm	d2 Ø mm	K mm	W Ø mm	BALENÍ		I Max. mm	 E mm	 (N)	 (N)	Kód zboží
						 vnitřní	 veškovní					
4,8	12,3	4,90-5,10	8,70	1,80	3,00			20,0	3,2 - 8,4	5100	3900	G182200 4812
	16,5											
6,5	16,5	6,60-7,00	10,10	2,00	4,00			26,5	3,0 - 12,0	11200	8800	G182200 6516
	22,5											



Pozn.: Tento nýt vyžaduje pro zanátyování speciální násadku!
Pro další informace ke správné aplikaci nás prosím kontaktujte.

NEREZOVÁ OCEL A2/NEREZOVÁ OCEL A2

PEVNOSTNÍ NÝTY STRUCTURAL
Plochá hlava

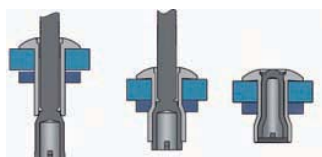





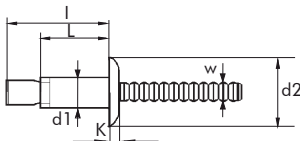





TĚLO: Nerezová ocel A2/304

TRN: Nerezová ocel A2/304



Testováno dle EN ISO 14589

d1 Ø mm	L Nominální mm	 mm	d2 Ø mm	K mm	W Ø mm	BALENÍ		I Max. mm	E MIN. mm MÁX.		 (N)	 (N)	Kód zboží
						 vnitřní	 veškovní						
4,8	10,3	4,90-5,10	9,70	1,80	3,00			18,5	1,5 - 6,8	5800	5000	G182600 4810	
	13,5							24,0	1,5 - 11,0			G182600 4813	
6,5	14,0	6,60-7,00	13,00	2,50	4,00			24,0	2,0 - 9,5	9900	8100	G182600 6514	
	20,0							33,0	2,0 - 16,0			G182600 6520	



Pozn.: Tento nýt vyžaduje pro zanátyvání speciální násadku!
Pro další informace ke správné aplikaci nás prosím kontaktujte.

NEREZOVÁ OCEL A2/NEREZOVÁ OCEL A2

PEVNOSTNÍ NÝTY STRUCTURAL
Zapuštěná hlava 100°

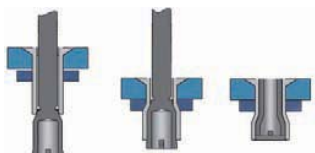





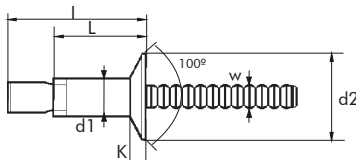



TĚLO: Nerezová ocel A2/304

TRN: Nerezová ocel A2/304



Testováno dle EN ISO 14589

d1 Ø mm	L Nominální mm	 mm	d2 Ø mm	K mm	W Ø mm	BALENÍ		I Max. mm	E MIN. mm MÁX.		 (N)	 (N)	Kód zboží
						 vnitřní	 veškovní						
6,5	16,5	6,60-7,00	10,60	2,00	4,00			26,0	3,0 - 12,0	9900	8100	G182700 6516	



Pozn.: Tento nýt vyžaduje pro zanátyvání speciální násadku!
Pro další informace ke správné aplikaci nás prosím kontaktujte.

PEVNOSTNÍ NÝTY HARDLOCK

Plochá hlava

HLINÍK/HLINÍK





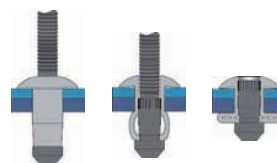
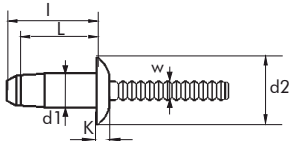

TĚLO: Hliník Al Mg 2,5 (AW5052)

TRN: Hliník



Testováno dle EN ISO 14589

d1 Ø mm	L Nominální mm	 mm	d2 Ø mm	K mm	W Ø mm	BALENÍ		I Max. mm	E mm		 (N)	 (N)	Kód zboží
						 vnitřní	 veknovní		MIN.	MÁX.			
6,4	10,5	6,70-6,90	13,10	2,60	4,20		1.500	15,0	2,8 - 4,8	5000	2800	G1881006410	
	12,5						1.000	17,0	4,8 - 6,8	5200	2800	G1881006412	
	14,5						1.000	19,0	6,8 - 8,8	5400	2800	G1881006414	
	16,5						1.000	21,0	8,8 - 10,8	5400	2800	G1881006416	
	18,5						1.000	23,0	10,8 - 12,8	5400	2800	G1881006418	

PEVNOSTNÍ NÝTY HARDLOCK

Plochá hlava

OCEL/OCEL





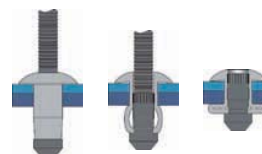
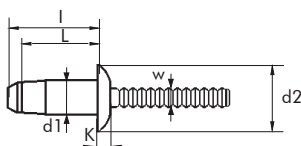

TĚLO: Pozinkovaná ocel A3K

TRN: Pozinkovaná ocel A2K



Testováno dle EN ISO 14589

d1 Ø mm	L Nominální mm	 mm	d2 Ø mm	K mm	W Ø mm	BALENÍ		I Max. mm	E mm		 (N)	 (N)	Kód zboží
						 vnitřní	 veknovní		MIN.	MÁX.			
6,4	10,5	6,70-6,90	13,10	2,60	4,00		1.500	15,0	2,8 - 4,8	12000	8800	G1884006410	
	12,5						1.000	17,0	4,8 - 6,8	12500	8800	G1884006412	
	14,5						1.000	19,0	6,8 - 8,8	14000	8800	G1884006414	
	16,5						1.000	21,0	8,8 - 10,8	15000	8800	G1884006416	
	18,5						1.000	23,0	10,8 - 12,8	16000	8800	G1884006418	
	20,5						1.000	25,0	12,8 - 14,8	16000	8800	G1884006420	
	22,5						1.000	27,0	14,8 - 16,8	16000	8800	G1884006422	

Pozn: Na dotaz umíme nabídnout výrobu nýtu hliník/hliník se zapuštěnou hlavou (d2).

NEREZOVÁ OCEL A2/NEREZOVÁ OCEL A2

PEVNOSTNÍ NÝTY HARDLOCK
Plochá hlava

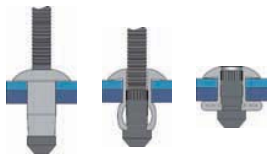



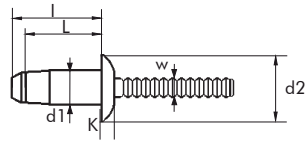

TĚLO: Nerezová ocel A2/304

TRN: Nerezová ocel A2/304



Testováno dle EN ISO 14589

d1 Ø mm	L Nominální mm	 mm	d2 Ø mm	K mm	W Ø mm	BALENÍ		I Max. mm	E mm		 (N)	 (N)	Kód zboží
						 vnitřní	 veknovní		MIN.	MÁX.			
6,4	14,5	6,70-6,90	13,10	2,60	4,00	1.000	1.000	19,0	6,8 - 8,8	13500	6500	G1886006415	
	16,5					1.000		21,0	8,8 - 10,8	13500	6500	G1886006417	

PEVNOSTNÍ NÝTY HARDGRIP Plochá hlava

OCEL/OCEL



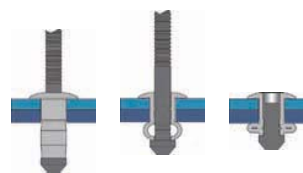
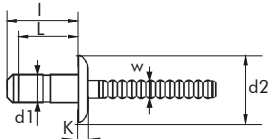

TĚLO: Pozinkovaná ocel A3K

TRN: Pozinkovaná ocel A2K



Testováno dle EN ISO 14589

d1 Ø mm	L Nominální mm		d2 Ø mm	K mm	W Ø mm	BALENÍ		I Max. mm	E mm				Kód zboží
						vnitřní	veškovní		MIN.	MÁX.			
3,2	7,0	3,30-3,50	6,50	1,00	2,00	500	4.000	10,00	1,0 - 3,0	1700	1450	01894003207	
	9,5					500	4.000	12,00	3,0 - 5,0	2000	1450	01894003210	
	11,5					500	4.000	15,00	5,0 - 7,0	2400	1450	01894003212	
4,0	7,5	4,10-4,30	7,70	1,30	2,60	500	4.000	10,50	1,0 - 3,0	2400	2800	01894004008	
	8,5					500	4.000	11,50	2,0 - 4,0	2600	2800	01894004009	
	9,5					500	3.000	12,50	3,0 - 5,0	3500	2800	01894004010	
	12,5					500	3.000	15,50	5,0 - 7,0	4100	2800	01894004013	
4,8	9,5	4,90-5,10	9,20	1,50	3,00	500	3.000	12,00	1,5 - 3,5	3500	3500	01894004809	
	11,5					250	2.000	14,50	3,5 - 6,0	4200	3500	01894004812	
	14,5					250	2.000	17,50	6,0 - 8,5	5600	3500	01894004815	
6,0	10,5	6,10-6,30	12,00	2,00	4,00		1.500	14,00	1,5 - 4,0	4200	5400	G1894006010	
	13,5						1.500	17,00	3,0 - 6,0	5400	5400	G1894006013	
	16,5						1.000	20,00	6,0 - 9,0	8500	5400	G1894006016	
	19,5						1.000	23,00	9,0 - 12,0	8500	5400	G1894006019	

Pozn: Na dotaz umíme nabídnout výrobu Rozpěrných Hardgrip nýtů se zapuštěnou hlavou (d2).

PEVNOSTNÍ NÝTY HARDGRIP Plochá hlava

NEREZOVÁ OCEL A2/NEREZOVÁ OCEL A2



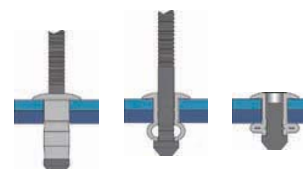
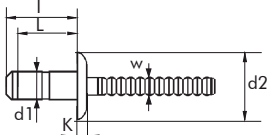

TĚLO: Nerezová ocel A2/304

TRN: Nerezová ocel A2/304



Testováno dle EN ISO 14589

d1 Ø mm	L Nominální mm		d2 Ø mm	K mm	W Ø mm	BALENÍ		I Max. mm	E mm				Kód zboží
						vnitřní	veškovní		MIN.	MÁX.			
3,2	7,0	3,30-3,40	6,50	1,00	2,10	500	4.000	10,00	1,0 - 3,0	2000	1700	01896003207	
	9,5					500	3.000	12,00	3,0 - 5,0			01896003210	
	11,5					500	3.000	15,00	5,0 - 7,0			01896003212	
4,0	7,5	4,20-4,40	7,70	1,30	2,60	500	4.000	10,50	1,0 - 3,0	5200	4000	01896004008	
	9,5					500	3.000	12,50	3,0 - 5,0			01896004010	
	12,5					500	3.000	15,50	5,0 - 7,0			01896004013	
4,8	9,5	5,00-5,20	9,20	1,20	3,20	500	3.000	13,00	1,5 - 3,5	5500	5000	01896004809	
	11,5					250	2.000	15,00	3,5 - 6,0			01896004812	
	14,5					250	2.000	18,00	6,0 - 8,5			01896004815	
	16,5					250	2.000	20,00	8,5 - 11,0			01896004817	

Pozn: Na dotaz umíme nabídnout výrobu Rozpěrných Hardgrip nýtů se zapuštěnou hlavou (d2).

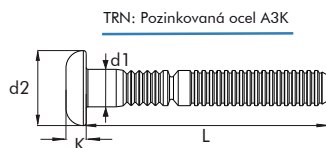
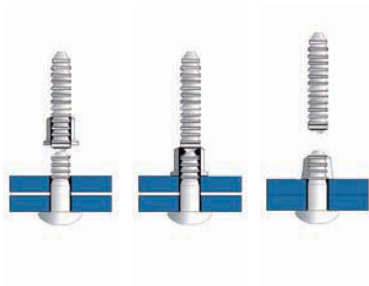

d1 Ø mm	L Nominalní mm		d2 Ø mm	K mm	BALENÍ vnitřní veknovní			E mm MIN. MÁX.	(N) (N)	Kód zboží
6,5	XX	6,60	13,0	3,50	2.000	*1,5	- 30,0			0742100 65XX
	XX									0762100 65XX

4 Vroubky
6 Vroubky

Pozn: Tato řada nýtů je dostupná na dotaz pro délky od 3,7 do 48 mm v závislosti na požadovaném svěrném rozsahu.



d1 Ø mm	L Nominalní mm	BALENÍ vnitřní veknovní	Kód zboží
10,3	9,0	2.000	0732200 6509

d1 Ø mm	L Nominalní mm	BALENÍ vnitřní veknovní	Kód zboží
10,3	8,0	2.000	0732200 6508

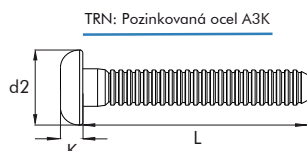
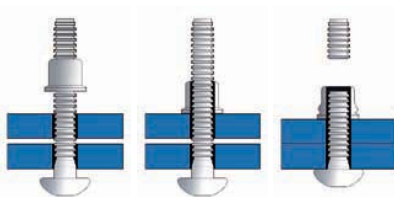

d1 Ø mm	L Nominalní mm		d2 Ø mm	K mm	BALENÍ vnitřní veknovní			E mm MÁX. MIN.	(N) (N)	Kód zboží TRN
6,5	57,0	6,60	13,00	3,4	1.000	1,6	- 31,7	11800	16000	0782100 6557

d1 Ø mm	L Nominalní mm	BALENÍ vnitřní veknovní	Kód zboží Závěrný kroužek
10,3	11,0	1.000	0732800 6511



Pozn.: Nýty Bralock se prodávají zvlášť kolík a zvlášť závěrný kroužek.





UZEMŇOVACÍ NÝTY

MĚĐ/OCEL

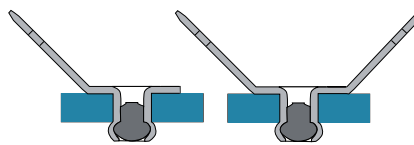
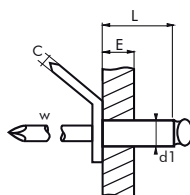
UZEMŇOVACÍ TĚLO: Mosaz

TRN: Poměděná ocel



d1 Ø m/m	L Nominalní m/m	 m/m	A m/m	B m/m	C m/m	W Ø m/m	BALENÍ  		 E m/m MÁX.	Kód zboží
4,0	7,0	4,10	6,30	8,50	0,80	2,40	250	1.500	4,0	01910004007
							250	1.500	4,0	01920004007

1 TAB
2 TAB





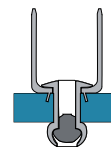
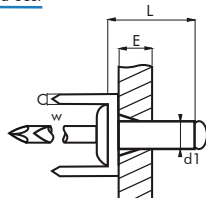

UZEMŇOVACÍ ČÁST: Mosaz

TRN: Poměděná ocel

TĚLO: Měď



d1 Ø m/m	L Nominalní m/m	 m/m	A m/m	B m/m	C m/m	W Ø m/m	BALENÍ  		 E m/m	Kód zboží
3,8	8,0	5,20	6,30	7,80	0,80	2,25	250	1.500	1,2	01920003808



BODOVACÍ HŘEBY

MĚĐ/OCEL

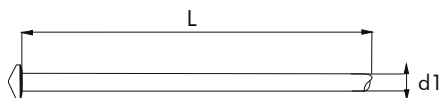

Poměděná ocel



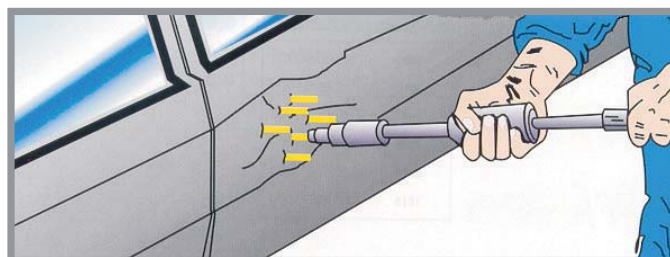

d1 Ø mm	L Nominalní mm	BALENÍ  		Kód zboží
2,0	50	500	4.000	04000002050
2,5	50	500	4.000	04000002550

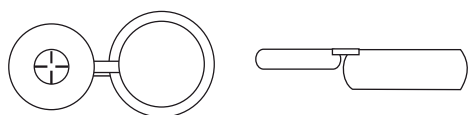

NYLON

KRYTKY NA NÝTY



Pro nýty d1 Ø m/m	RAL	BALENÍ		Kód zboží
		 vnitřní	 veškovní	
3,2 4,0 4,8	Černá 9005	500	4.000	07000N09000
	Bílá	500	4.000	07000BL9000
	Žlutá 1004	500	4.000	07000J19000
	Šedá 7035	500	4.000	07000G09000
	Hnědá 8014	500	4.000	07000M09000
	Běžová 1015	500	4.000	07000BE9000
	Modrá 5002	500	4.000	07000A59000



Pozn.: Nylonové krytky mohou být použity u nýtů do průměru hlavy 9,5mm.

NYLON

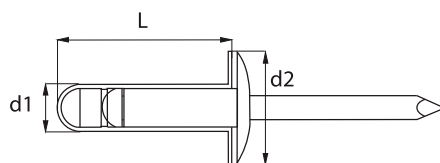
ČEPIČKA PRO NÝTY



L Nominální m/m	d1 Ø m/m	d2 Ø m/m
21,8	5,80	14,0

Pro nýty d1 Ø m/m	RAL	BALENÍ		Kód zboží
		 vnitřní	 veškovní	
4,8	Černá 9005	250	1.000	07000N1400

PODLOŽKY POD NÝTY

OCEL

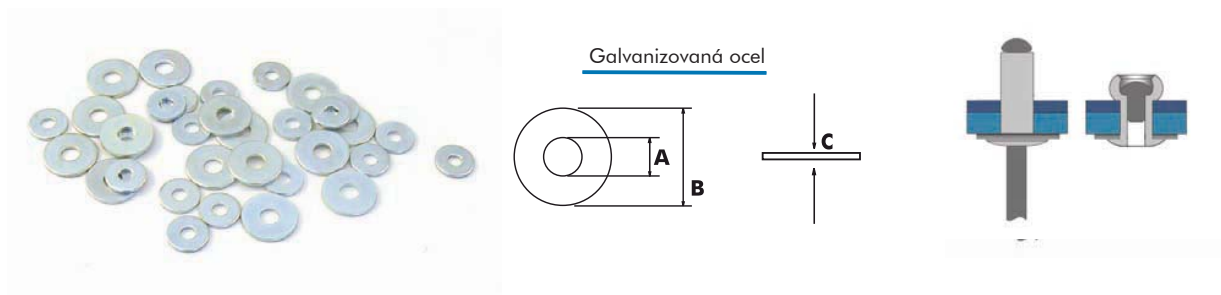

Pod Nýty d1 Ø m/m	A m/m	B m/m	C m/m	BLISTRY		Kód zboží
2,4	2,50	9,00	1,00	1000	10.000	07210002400
3,0	3,10	9,00	1,00	1000	10.000	07210003000
3,2	3,30	9,50	1,00	1000	10.000	07210003200
4,0	4,10	12,00	1,00	500	5.000	07210004000
4,8	4,90	15,00	1,50	250	2.500	07210004800
5,0	5,10	15,00	1,50	250	2.500	07210005000
6,0	6,10	15,00	1,50	250	2.500	07210006000
6,4	6,50	15,00	1,50	250	2.500	07210006400

PODLOŽKY POD NÝTY

NEOPREN

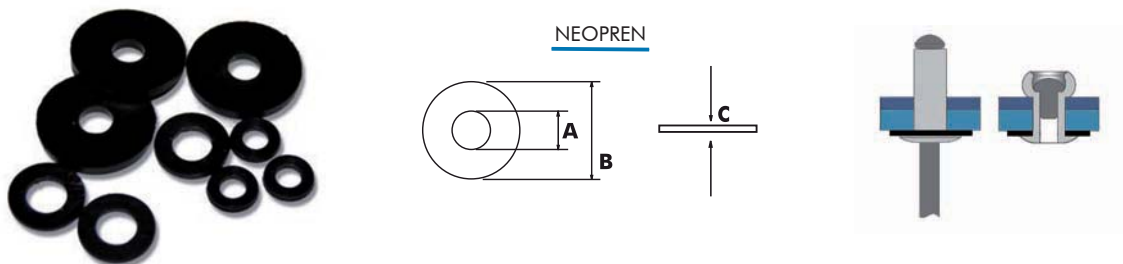

Pod Nýty d1 Ø m/m	A m/m	B m/m	C m/m	BLISTRY		Kód zboží
3,2	3,00	6,00	0,80	1000	10.000	07020603001
4,0	3,80	7,00	0,80	1000	10.000	07020703801
4,0 4,8 Velká hlava Ø14 Ø15 Ø16	4,00	14,00	1,30	500	5.000	07020144001
4,8	4,60	9,00	0,80	1000	10.000	07020904601
5,0	5,00	8,00	1,30	1000	10.000	07020805001

Pozn.: Minimální balení je krabice s 10 blistry.

Zásobníkové nýty

Zásobníkové nýty SPEED RIVETS: synonymum rychlosti a efektivity. Jsou dodávány na papírových páscích a používány pro magazínové nýtování při použití jednoho trnu. Použití zásobníkových nýtů SPEED RIVETS zaručuje rychlé a kvalitní spojení zvyšující produktivitu. Bez přerušení je možné zanýtovat až 60 nýtů za minutu.

BSR

Vhodné pro aplikace do kovů, plastů a slitin hliníku.

Vyšší produktivita

Radiální roztažení během aplikace.

Dobrá odolnost na střihu.



BSV

Navrženy pro aplikace s měkkým, či málo odolným materiálem

Vysoce precizní a kvalitní spoj.

Skvěle vyplňuje otvor v aplikaci.

Dobrá odolnost na střihu.

POUŽITÍ

Tyto nýty jsou dodávány na papírových páscích a používány pro magazínové nýtování při použití jednoho trnu. Na konci nýtovacího cyklu každého nýtu se automaticky další nýt připraví v násadce pro okamžitou aplikaci.



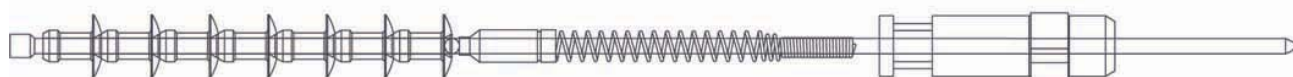

Je tomu tak díky rozšířenému a tvarově upravenému konci nýtu. Výsledkem je kvalitní spojovací prvek s dobrou sřihovou odolností.

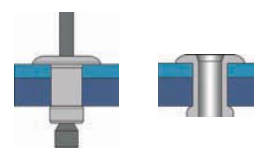
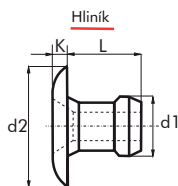

SPEED RIVET BSR Plochá hlava

HLINÍK







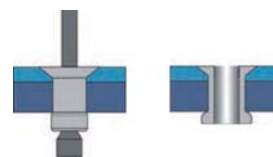
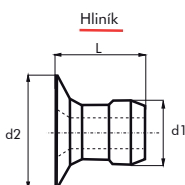

d1 Ø m/m	L Nominální m/m	 m/m	d2 Ø		K m/m	 počet kusů	BALENÍ  vekovní	E m/m		 (N)	 (N)	Kód zboží
			MIN.	MÁX.				MIN.	MÁX.			
3,2	4,3	3,26-3,34	5,9	6,4	1,00	58	30.000	1,20 - 2,40	720	1260		G1550003204
	5,3											G1550003205
	6,3											G1550003206
	7,3											G1550003207
	8,3											G1550003208
	9,3											G1550003209
4,0	4,9	3,97-4,04	7,5	8,0	1,00	52	23.000	1,60 - 2,90	1100	1700		G1550004005
	5,9											G1550004006
	6,9											G1550004007
	7,9											G1550004008
	8,9											G1550004009
4,8	6,1	4,85-4,93	9,0	9,6	1,20	42	15.000	2,15 - 3,90	1490	2250		G1550004806
	7,3											G1550004807
	8,6											G1550004808
	9,9											G1550004809
	11,1											G1550004811

Pozn: Tato řada je vyráběná na základě poptávky. Pro informace ohledně minimálního množství a dodacích termín nás prosím kontaktujte.

SPEED RIVET BSR Zapuštěná hlava







HLINÍK

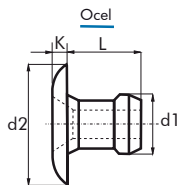
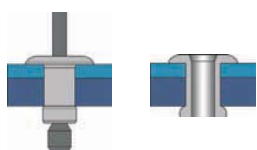

d1 Ø m/m	L Nominální m/m	 m/m	d2 Ø		 počet kusů	BALENÍ  vekovní	E m/m		 (N)	 (N)	Kód zboží
			MIN.	MÁX.			MIN.	MÁX.			
3,2	4,8	3,26-3,34	5,1	5,9	65	30.000	1,60 - 2,70	700	1000		G1552003204
	5,8										G1552003205
	6,8										G1552003206
	7,8										G1552003207
	8,8										G1552003208
4,0	5,2	3,97-4,04	6,1	6,9	58	25.000	1,60 - 2,90	1100	1700		G1552004005
	5,7										G1552004055
	6,2										G1552004006
	7,2										G1552004007
	8,2										G1552004008
	9,2										G1552004009







Pozn: Tato řada je vyráběná na základě poptávky. Pro informace ohledně minimálního množství a dodacích termín nás prosím kontaktujte.

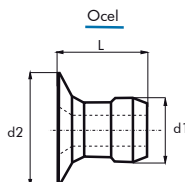
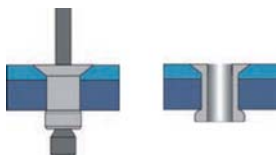

d1 Ø m/m	L Nominalní m/m	 m/m	d2 Ø MIN. m/m MÁX.	K m/m	 počet kusů	BALENÍ  vekvovní	 E MIN. m/m MÁX.	 (N)	 (N)	Kód zboží
3,2	3,8	3,26-3,34	5,9 6,4	1,10	65	30.000	1,00 - 1,90	1100	1800	G1560003203
	4,3				58	30.000	1,20 - 2,40			G1560003204
	5,3				48	25.000	2,20 - 3,40			G1560003205
	6,3				42	20.000	3,20 - 4,40			G1560003206
	7,3				37	20.000	4,20 - 5,40			G1560003207
	8,3				33	15.000	5,20 - 6,40			G1560003208
	9,3				30	15.000	6,20 - 7,50			G1560003209
4,0	4,9	3,97-4,04	7,5 8,0	1,00	52	23.000	1,60 - 2,90	1600	2800	G1560004005
	5,4				44	20.000	2,20 - 3,40			G1560004055
	5,9				44	20.000	2,70 - 3,90			G1560004006
	6,9				38	17.000	3,70 - 4,90			G1560004007
	7,9				34	15.000	4,70 - 5,90			G1560004008
	8,9				30	13.000	5,70 - 6,90			G1560004009
4,8	5,4	4,85-4,93	9,0 9,6	1,20	46	15.000	1,70 - 3,30	2200	3700	G1560004805
	6,1				42	15.000	2,10 - 3,90			G1560004806
	7,3				36	13.000	3,70 - 5,20			G1560004807
	8,6				31	11.000	5,00 - 6,40			G1560004808
	9,9				28	10.000	6,30 - 7,70			G1560004809
	11,1				24	9.000	7,50 - 9,00			G1560004811

Pozn: Tato řada je vyráběna na základě poptávky. Pro informace ohledně minimálního množství a dodacích termínů nás prosím kontaktujte.



d1 Ø m/m	L Nominalní m/m	 m/m	d2 Ø MIN. m/m MÁX.	 počet kusů	BALENÍ  vekvovní	 E MIN. m/m MÁX.	 (N)	 (N)	Kód zboží
3,2	4,3	3,26-3,34	5,1 5,9	70	30.000	1,30 - 2,00	900	1600	G1562003203
	4,8			65	30.000	1,60 - 2,70			G1562003204
	5,8			52	25.000	2,60 - 3,80			G1562003205
	6,8			44	20.000	3,60 - 4,80			G1562003206
	7,8			38	20.000	4,60 - 5,80			G1562003207
	8,8			34	17.000	5,60 - 6,80			G1562003208
4,0	5,2	3,97-4,04	6,1 6,9	58	25.000	1,60 - 2,90	1600	2800	G1562004005
	5,7			54	23.000	2,20 - 3,40			G1562004055
	6,2			49	20.000	2,70 - 3,90			G1562004006
	7,2			42	20.000	3,70 - 4,90			G1562004007
	8,2			36	15.000	4,70 - 5,90			G1562004008
	9,2			32	15.000	5,70 - 6,90			G1562004009





Pozn: Tato řada je vyráběna na základě poptávky. Pro informace ohledně minimálního množství a dodacích termínů nás prosím kontaktujte.

SPEED RIVET BSR

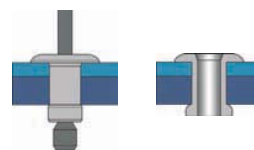
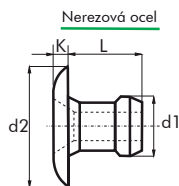
Plochá hlava

NEREZOVÁ OCEL A2



d1 Ø m/m	L Nominalní m/m	 m/m	d2 Ø		K m/m	 počet kusů	BALENÍ  veknovní	E m/m		 (N)	 (N)	Kód zboží
			MIN.	MÁX.				MIN.	MÁX.			
3,2	4,3	3,27-3,34	5,8	6,4	1,00	58	30.000	1,20 - 2,40	1300	2000		G1570003204
	5,3							2,20 - 3,40				G1570003205
	6,3							3,20 - 4,40				G1570003206
4,0	4,9	3,97-4,04	7,5	8,0	1,00	52	23.000	1,60 - 2,90	2400	3500		G1570004004
	5,4							2,20 - 3,40				G1570004005
	5,9							2,70 - 3,90				G1570004006
	6,9							3,70 - 4,90				G1570004007
4,8	5,4	4,85-4,93	9,0	9,6	1,20	46	15.000	1,70 - 3,30	3500	5100		G1570004805
	6,1							2,10 - 3,90				G1570004806
	7,3							3,70 - 5,20				G1570004807





Pozn: Tato řada je vyráběná na základě poptávky. Pro informace ohledně minimálního množství a dodacích termín nás prosím kontaktujte.

SPEED RIVET BSV

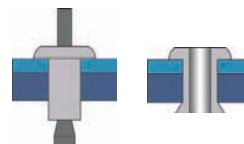
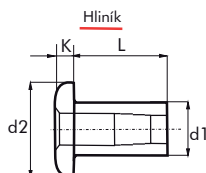
Plochá hlava







HLINÍK

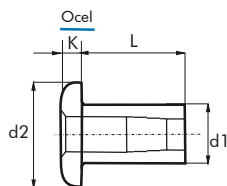
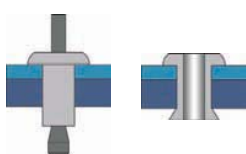

d1 Ø m/m	L Nominalní m/m	 m/m	d2 Ø		K m/m	 počet kusů	BALENÍ  veknovní	E m/m		 (N)	 (N)	Kód zboží
			MIN.	MÁX.				MIN.	MÁX.			
3,2	3,2	3,30-3,35	4,9	5,5	1,20	70	30.000	0,50 - 1,60	500			G1510003203
	4,8							1,60 - 3,20				G1510003205
	6,4							3,20 - 4,80				G1510003206
	7,9							4,80 - 6,40				G1510003207
	9,5							6,40 - 7,90				G1510003209
	11,1							7,90 - 9,50				G1510003211
4,0	4,8	4,10-4,15	5,9	6,5	1,50	46	20.000	1,60 - 3,20	700			G1510004004
	6,4							3,20 - 4,80				G1510004006
	7,9							4,80 - 6,40				G1510004007
	9,5							6,40 - 7,90				G1510004009
	11,1							7,90 - 9,50				G1510004011
4,8	5,6	4,85-4,95	8,3	8,9	1,80	38	13.000	1,60 - 3,20	1000			G1510004805
	7,2							3,20 - 4,80				G1510004807
	8,8							4,80 - 6,40				G1510004808
	10,3							6,40 - 7,90				G1510004810
	11,9							7,90 - 9,50				G1510004811







Pozn: Tato řada je vyráběná na základě poptávky. Pro informace ohledně minimálního množství a dodacích termín nás prosím kontaktujte.

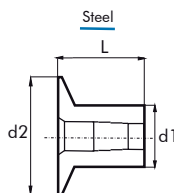
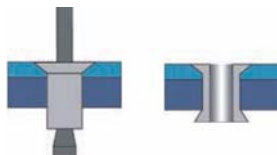

d1 Ø m/m	L Nominální m/m	 m/m	d2 Ø MIN. m/m MÁX.	K m/m	 počet kusů	BALENÍ  vekovní	 E MIN. m/m MÁX.	 (N)	 (N)	Kód zboží
3,2	3,2	3,28-3,34	4,9 5,5	1,20	70	30.000	0,50 - 1,60	1000		G1520003203
	4,8				51	25.000	1,60 - 3,20			G1520003205
	6,4				38	20.000	3,20 - 4,20			G1520003206
	7,9				32	17.000	4,80 - 6,40			G1520003207
	9,5				27	15.000	6,40 - 7,90			G1520003209
	11,1				23	12.000	7,90 - 9,50		G1520003211	
4,0	4,8	4,09-4,16	5,9 6,5	1,50	46	20.000	1,60 - 3,20	1400		G1520004004
	6,4				38	17.000	3,20 - 4,40			G1520004006
	7,9				34	15.000	4,80 - 6,40			G1520004007
	9,5				27	12.000	6,40 - 7,90			G1520004009
	11,1				23	9.000	7,90 - 9,50			G1520004011
4,8	5,6	4,85-4,93	8,3 8,9	1,80	38	13.000	1,60 - 3,20	2400		G1520004805
	7,2				33	12.000	3,20 - 4,80			G1520004807
	8,8				28	10.000	4,80 - 6,40			G1520004808
	10,3				24	9.000	6,40 - 7,90			G1520004810
	11,9				22	8.000	7,90 - 9,50			G1520004812

Pozn: Tato řada je vyráběná na základě poptávky. Pro informace ohledně minimálního množství a dodacích termínů nás prosím kontaktujte.



d1 Ø m/m	L Nominální m/m	 m/m	d2 Ø MIN. m/m MÁX.	 počet kusů	BALENÍ  vekovní	 E MIN. m/m MÁX.	 (N)	 (N)	Kód zboží
3,2	3,2	3,28-3,34	5,2 5,8	70	30.000	0,50 - 1,60	1000		G1522003203
	4,0			70	30.000	1,00 - 2,40			G1522003204
	4,8			65	30.000	1,60 - 3,20			G1522003205
	6,4			46	20.000	3,20 - 4,80			G1522003206
	8,1			37	15.000	4,80 - 6,40			G1522003208
	9,5			34	15.000	6,40 - 7,90		G1522003209	
4,0	4,8	4,09-4,16	6,2 6,8	62	20.000	1,60 - 3,20	1400		G1522004004
	6,4			46	20.000	3,20 - 4,80			G1522004006
	8,1			37	15.000	4,80 - 6,40			G1522004008
	9,5			31	13.000	6,40 - 7,90			G1522004009
	11,2			27	12.000	7,90 - 9,50			G1522004011
4,8	5,6	4,85-4,93	8,6 9,2	52	15.000	1,60 - 3,20	2400		G1522004805
	7,2			41	15.000	3,20 - 4,80			G1522004807
	8,8			33	10.000	4,80 - 6,40			G1522004808
	10,3			28	10.000	6,40 - 7,90			G1522004810
	11,9			24	9.000	7,90 - 9,50			G1522004812

Pozn: Tato řada je vyráběná na základě poptávky. Pro informace ohledně minimálního množství a dodacích termínů nás prosím kontaktujte.

NÝTOVACÍ MATICE

Nýtovací matice BRALO jsou rychlý, jednoduchý a spolehlivý spojovací materiál s vysokou kvalitou a odolností.

Nýtovací matice slouží k získání závitů v aplikacích v tenkých či měkkých materiálech.

Jsou vhodné pro použití v aplikacích s přístupem z jedné strany.



Instalace je možná v jakékoliv fázi výroby, dokonce i po lakování.

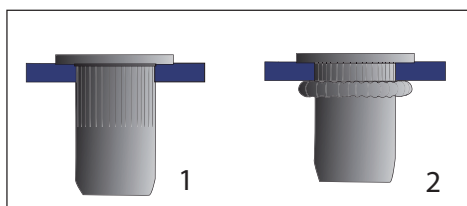

1. Našroubujte matici na trn kleští a potom vložte do otvoru v aplikaci. Pohybem páky kleští se trn zatáhne do kleští a tím se roztáhne matice po obvodu, čímž dojde k sevření v materiálu.

2. Po aplikaci je nýtovací matice kratší. Vyšroubováním trnu z matice je aplikace dokončena.

ROZMĚRY

d1 Průměr těla matice

d2 Průměr hlavy matice

L Délka těla matice

D Velikost vnitřního závitů

K Výška hlavy

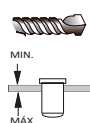

Průměr otvoru (mm)

Svěrný rozsah (mm)

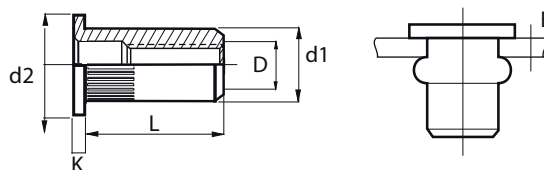

PEVNOSTI

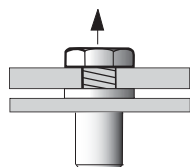

Síla k aplikaci (N)

Jedná se o sílu tahovou, potřebnou k zanýtování matice.

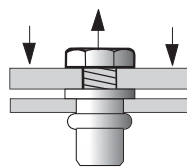

Tahová pevnost závitů (N)

Vzniká působením dvou protichůdných sil působících k rovnoběžné ose matice.

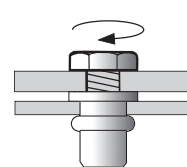

Pevnost kluzu (Nm)

Jedná se o mezní sílu možnou použít k utažení šroubu tak, aby nedošlo k poškození v aplikaci.

Typy nýtovacích matic

VÝBĚR NÝTOVACÍ MATICE

PRŮMĚR HLAVY:

BRALO nabízí širokou škálu provedení pro velikosti závitů od M3 po M12.

Výběr hlavy závisí na materiálu aplikace.

VÝBĚR TYPU NÝTOVACÍ MATICE:

Nabízíme pět typů nýtovacích matic BRALO: hladká, vroubkovaná, částečně šestihranná, šestihranná a nýtovací šroub.

Tloušťka MATERIÁLU:

Je důležité zvolit matici, která odpovídá svěrným rozsahem tloušťce materiálu v aplikaci.

ODOLNOST VŮČI KOROZI:

Pro omezení rizika vzniku koroze působením okolního materiálu v aplikaci používáme zinkování, různé ochranné povrchové úpravy (Delta Seal, galvanizace, anodizace, niklování) a lakování, které chrání matici před stykem s okolím.

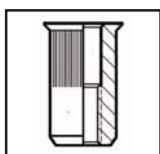

ZAPUŠTĚNÁ REDUKOVANÁ HLAVA

Nízká malá hlava, bez potřeby zahloubení materiálu, přičemž zásadně nenarušuje vzhled rovné plochy.

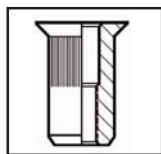

ZAPUŠTĚNÁ HLAVA

Tento typ hlavy slouží k vytvoření zcela rovné plochy v aplikaci, vyžaduje zahloubení materiálu.

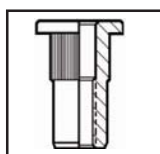

VELKÁ HLAVA

Poskytuje velkou styčnou plochu, která slouží k lepšímu upevnění, zároveň může sloužit k vymezení dvou spojovaných ploch.



OTEVŘENÉ PŘÍKROVÍ

Umožňuje použití libovolně dlouhého šroubu.



UZAVŘENÉ PŘÍKROVÍ

Tento typ matice je ideální pro použití tam, kde je potřeba vodotěsnost v aplikaci.

TYPY NÝTOVACÍCH MATIC



HLADKÁ NÝTOVACÍ MATICE

Matice válcovitého provedení s hladkým tělem, navržena pro odolné materiály. Výborné řešení pro získání kvalitního závitu v materiálech o malé tloušťce. Základní odolnost vůči protočení. Použití do kulatých otvorů.

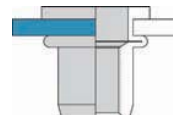

VROUBKOVANÁ NÝTOVACÍ MATICE

Matice válcovitého provedení s vroubkovaným tělem. Zvýšená odolnost vůči protočení. Ideální pro aplikace v tenkém kovovém materiálu, trubkovitých materiálech, či plastech (některé typy) Použití do kulatých otvorů.

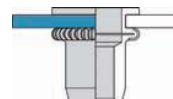

ŠESTIHRANNÁ NÝTOVACÍ MATICE

Nabízí nekompromisní mechanickou odolnost. Vysoká odolnost vůči protočení. Použití do šestihranných otvorů.

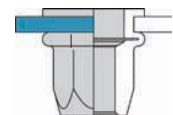

ČÁSTEČNĚ ŠESTIHRANNÁ NÝTOVACÍ MATICE

Nabízí nekompromisní mechanickou odolnost. Vysoká odolnost vůči protočení. Použití do šestihranných otvorů. Válcovitý konec těla pro snazší vkládání do děr.

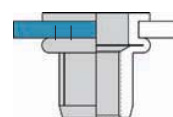

NÝTOVACÍ ŠROUB

Slouží k jednoduchému získání pevného šroubu. Obzvláště hodný pro díly s omezeným přístupem. Rychlá a jednoduchá instalace. Časté použití ve vzduchotechnice a elektrotechnice.

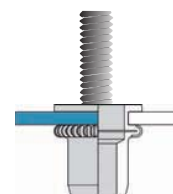

NÝTOVACÍ MATICE HLADKÉ



Velká hlava – Otevřená

OCEL

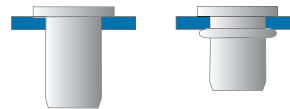
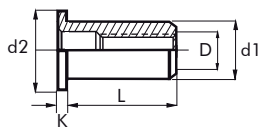

Pozinkovaná ocel A3K



D	E MIN. mm MÁX.	L Nominální mm	d1 Ø mm	d2 Ø mm	K mm	mm	BALENÍ		 (N)	 (N)	 (Nm)	Kód zboží
							vnitřní	veškovní				
M 4	0,5 - 2,0	9,50	5,90	9,00	1,00	6,10	500	4.000	4400	7900	3,0	0301104006
	2,0 - 4,0	12,25					500	4.000				0301114006
M 5	0,5 - 3,0	12,00	6,90	10,00	1,00	7,10	500	4.000	5300	9800	4,8	0301105007
	3,0 - 5,5	15,00					500	4.000				0301115007
	5,5 - 8,0	18,00					500	3.000				0301185007
M 6	0,5 - 3,0	14,50	8,90	13,00	1,50	9,10	250	2.000	6500	19100	12,0	0301106009
	3,0 - 5,5	16,50					250	1.500				0301116009
	5,5 - 8,0	21,50					250	1.500				0301186009
M 8	0,5 - 3,0	16,50	10,90	16,00	1,50	11,10	250	1.500	8350	29800	23,0	0301108011
	3,0 - 5,5	18,50					200	1.200				0301118011
	5,5 - 8,0	22,50					150	900				0301188011
	8,0 - 10,5	25,50					150	900				03011108011
M 10	1,0 - 3,5	17,50	11,90	16,00	1,70	12,10	150	900	12000	34000	30,0	0301101012
M 10	1,0 - 3,5	19,50	12,90	19,00	2,00	13,10	150	900	11000	43300	30,0	0301101013
	3,5 - 6,0	21,50					100	600				0301111013
	5,5 - 8,0	27,00						500				G301181013
M 12	1,0 - 4,0	25,00	15,90	23,00	2,00	16,10		500	18000	>57800	54,0	G301101216

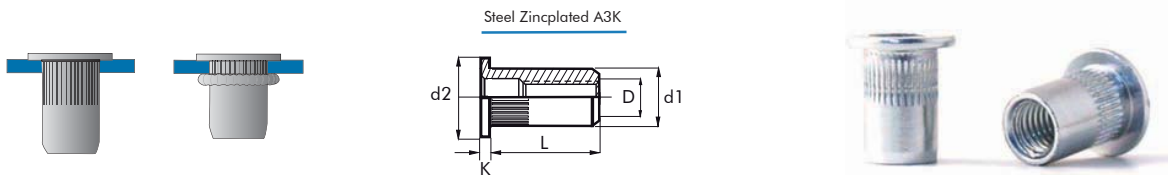

D	E MIN. mm MÁX.	L Nominální mm	d1 Ø mm	d2 Ø mm	K mm	mm	BALENÍ		(N)	(N)	(Nm)	Kód zboží			
							vnitřní	veškovní							
M 3	0,25 - 2,5	10,50	4,90	8,00	1,00	5,10	500	4.000	2400	4100	2,2	0371103005			
M 4	0,5 - 3,0	9,50	5,90	9,00	1,00	6,10	500	4.000	3900	7900	4,5	0371104006			
	3,0 - 4,5	12,25											500	4.000	0371114006
M 5	0,5 - 3,0	12,00	6,90	10,00	1,00	7,10	500	4.000	5700	12000	6,4	0371105007			
	3,0 - 5,5	15,00											500	4.000	0371115007
M 6	0,5 - 3,0	14,50	8,90	13,00	1,50	9,10	250	2.000	6000	20000	17,8	0371106009			
	3,0 - 5,5	16,50											250	1.500	0371116009
	0,5 - 2,0	13,00											250	2.000	0371136009
M 8	0,5 - 3,0	16,50	10,90	16,00	1,50	11,10	250	1.500	8400	29800	34,5	0371108011			
	3,0 - 5,5	18,50											200	1.200	0371118011
M 10	1,0 - 3,5	19,50	12,90	19,00	2,00	13,10	150	900	11000	43300	60,0	0371101013			
	3,5 - 6,0	21,50											100	600	0371111013
	2,4 - 4,0	19,50												1.000	G371121013
M 12	1,0 - 4,0	25,00	15,90	23,00	2,00	16,10		500	14700	47700	161,5	0371101216			

NÝTOVACÍ MATICE HLADKÉ





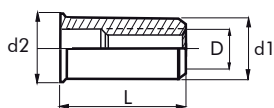

Redukovaná zapuštěná hlava – otevřená

OCEL









Pozinkovaná ocel A3K



D	 MIN. mm MÁX.	L Nominální mm	d1 Ø mm	d2 Ø mm	 mm	BALENÍ		 (N)	 (N)	 (Nm)	Kód zboží
						 vnitřní	 veškovní				
M 3	0,5 - 1,5	8,70	4,65	5,40	5,10	500	4.000	2100	3650	1,7	0301203005
M 4	0,5 - 2,0	10,40	6,30	6,70	6,40	500	4.000	3400	7200	2,8	0301204006
M 5	0,5 - 3,0	11,50	7,10	7,90	7,20	500	4.000	5300	9800	5,7	0301205007
M 6	0,5 - 3,0	14,50	9,50	10,60	9,60	500	3.000	6500	19100	6,5	0301206009
M 8	0,5 - 3,0	16,00	10,50	11,60	10,60	250	1.500	8350	29800	8,6	0301208011

Pro palcové rozměry otvorů.





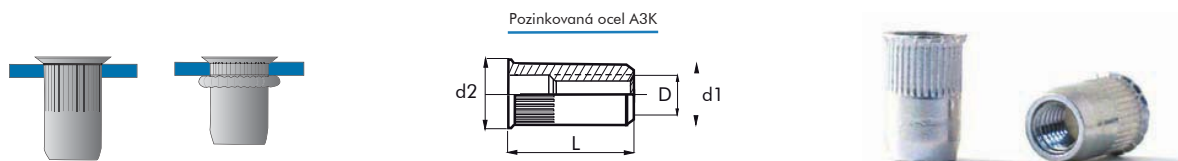

D	 MIN. mm MÁX.	L Nominální mm	d1 Ø mm	d2 Ø mm	 mm	BALENÍ		 (N)	 (N)	 (Nm)	Kód zboží
						 vnitřní	 veškovní				
M 4	0,5 - 2,0	10,00	5,90	7,00	6,00	500	4.000	3400	7200	2,8	0301204005
M 5	0,5 - 3,0	12,00	6,90	8,00	7,00	500	4.000	5300	9800	5,7	0301205006
M 6	0,5 - 3,0	15,00	8,90	10,00	9,00	500	3.000	6500	19100	6,5	0301206008
M 8	0,5 - 3,0	16,00	10,90	12,00	11,00	250	1.500	8350	29800	8,6	0301208010

Pro metrické rozměry otvorů

OCEL

NÝTOVACÍ MATICE VROUBKOVANÉ Redukovaná zapuštěná hlava – otevřená







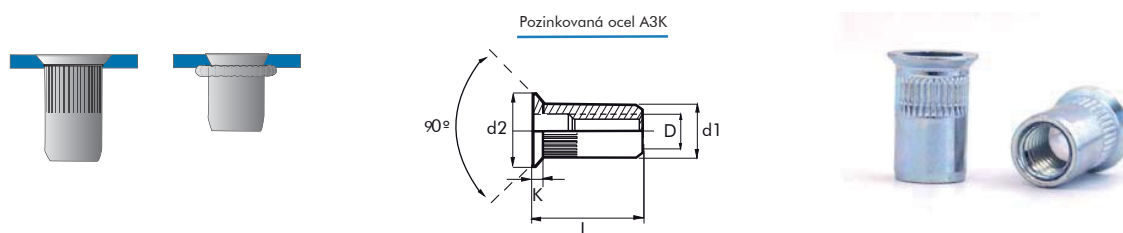

D	 E MIN. mm MÁX.	L Nominální mm	d1 Ø mm	d2 Ø mm	 mm	BALENÍ		 (N)	 (N)	 (Nm)	Kód zboží
						 vnitřní	 veknovní				
M 4	0,5 - 2,0	10,40	5,90	7,00	6,10	500	4.000	3900	7900	2,9	0371204006
M 5	0,5 - 3,0	11,50	6,90	8,00	7,10	500	4.000	5800	9800	6,0	0371205007
M 6	0,5 - 3,0	14,50	8,90	10,00	9,10	500	3.000	6500	16500	10,1	0371206009
	3,0 - 5,5	16,50									
M 8	0,5 - 3,0	16,80	10,90	12,00	11,10	250	1.500	8400	29800	15,5	0371208011
	3,0 - 5,5	18,50									
M 10	0,7 - 3,5	21,00	12,90	14,00	13,10	150	900	11000	43300	20,0	0371201013
	3,0 - 5,5	23,50									
M 12	1,0 - 3,5	24,20	15,90	17,00	16,10	500		17200	57800	30,0	G371201216

OCEL

NÝTOVACÍ MATICE VROUBKOVANÉ Zapuštěná hlava – otevřená



D	 E MIN. mm MÁX.	L Nominální mm	d1 Ø mm	d2 Ø mm	K mm	 mm	BALENÍ		 (N)	 (N)	 (Nm)	Kód zboží
							 vnitřní	 veknovní				
M 4	1,5 - 3,0	11,00	5,90	8,50	1,50	6,10	500	4.000	3900	7900	3,3	0371304006
M 5	1,5 - 4,0	13,00	6,90	10,00	1,50	7,10	500	4.000	5800	9800	6,5	0371305007
M 6	1,5 - 4,0	16,00	8,90	12,00	1,50	9,10	250	2.000	7100	19600	20,0	0371306009
M 8	1,5 - 4,0	18,50	10,90	13,50	1,50	11,10	250	1.500	8400	29800	22,0	0371308011
	2,0 - 4,5	18,50										
M 10	1,5 - 4,5	22,00	12,90	16,00	1,50	13,10	150	900	11000	43300	34,6	0371301013

NÝTOVACÍ MATICE VROBKOVANÉ

Extra velká hlava – otevřená

OCEL



Pozinkovaná ocel A3K

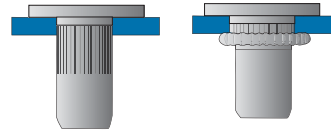
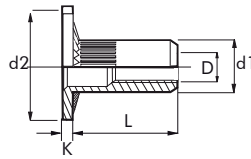

D	E MIN. mm MÁX.	L Nominální mm	d1 Ø mm	d2 Ø mm	K mm	BALENÍ vnitřní vekovní	Kód zboží				
							(N)	(N)	(Nm)		
M 5	3,0 - 5,0	17,70	8,95	18,50	1,50	9,10	1.000	8700	9800	9,1	G371705009T1
M 6	3,0 - 5,0	17,70	8,95	18,50	1,50	9,10	1.000	8700	19100	13,0	G371706009T



NÝTOVACÍ MATICE ŠESTIHRANNÉ

Plochá hlava – otevřená

OCEL



Pozinkovaná ocel A3K

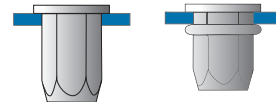
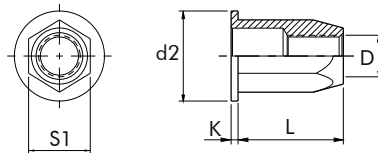

D	E MIN. mm MÁX.	L Nominální mm	S1 mm	d2 Ø mm	K mm	BALENÍ vnitřní vekovní	Kód zboží					
							(N)	(N)	(Nm)			
M 4	0,5 - 2,0	10,00	5,90	9,00	1,00	6,10	500	4.000	3400	7900	4,8	0311104006
M 5	0,5 - 3,0	13,00	6,90	10,00	1,00	7,10	500	4.000	4900	9800	6,5	0311105007
M 6	0,5 - 3,0	14,20	8,90	13,00	1,50	9,10	250	2.000	7100	22000	21,4	0311106009
M 8	0,5 - 3,0	16,50	10,90	16,00	1,50	11,10	250	1.500	9600	29800	40,0	0311108011
	3,0 - 5,5	19,50										
M 10	0,5 - 3,5	19,50	12,90	19,00	2,00	13,10	150	900	12600	43300	88,0	0311101013
M 12	1,0 - 4,0	25,00	16,00	23,00	2,00	16,10	500		17200	>57800	115,0	0311101216

OCEL

NÝTOVACÍ MATICE ČÁSTEČNĚ ŠESTIHRANNÉ Plochá hlava – otevřená

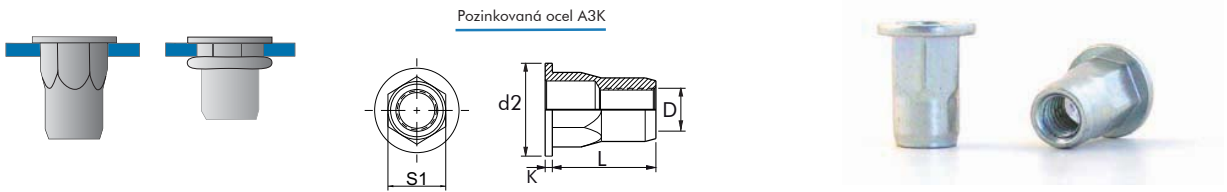

Pozinkovaná ocel A3K

D	E MIN. mm MÁX.	L Nominalní mm	S1 Ø mm	d2 Ø mm	K mm	Ø mm	BALENÍ		(N)	(N)	(Nm)	Kód zboží
							vnitřní	veškovní				
M 4	0,5 - 2,5	10,00	5,90	9,00	1,00	6,10	500	4.000	3400	7900	3,3	0334104006
M 5	0,5 - 3,0	12,50	6,90	10,00	1,00	7,10	500	4.000	4900	9800	6,2	0334105007
M 6	0,5 - 3,0	14,50	8,90	13,00	1,50	9,10	250	2.000	7100	19100	14,7	0334106009

OCEL

NÝTOVACÍ MATICE ČÁSTEČNĚ ŠESTIHRANNÉ Plochá hlava – otevřená

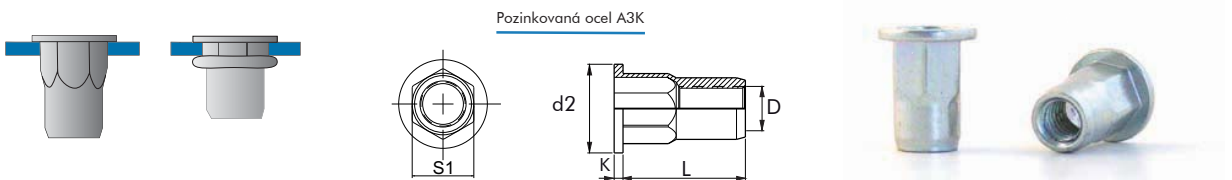

Pozinkovaná ocel A3K

D	E MIN. mm MÁX.	L Nominalní mm	d1 Ø mm	d2 Ø mm	K mm	Ø mm	BALENÍ		(N)	(N)	(Nm)	Kód zboží
							vnitřní	veškovní				
M 6	0,5 - 3,0	14,50	8,90	13,00	1,50	9,10	250	2.000	7100	19100	14,7	0331106009
M 8	0,5 - 3,0	16,50	10,90	16,00	1,50	11,10	250	1.500	7500	19300	20,0	0331108011
M 12	1,0 - 4,0	25,00	15,90	23,00	2,00	16,10		500	17200	44000	115,0	0331101216

NÝTOVACÍ MATICE ŠESTIHRANNÉ





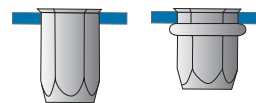
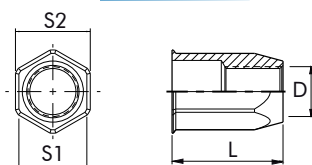

Redukovaná zapuštěná hlava – otevřená

OCEL



Pozinkovaná ocel A3K



D	 E MIN. mm MÁX.	L	S1	S2	 mm	BALENÍ		 (N)	 (N)	 (Nm)	Kód zboží
						 vnitřní	 veknovní				
M 4	0,5 - 2,0	11,00	5,90	6,60	6,10	500	4.000	3400	7900	4,1	0311204006
M 5	0,5 - 3,0 3,0 - 5,5	14,00 16,50	6,90	8,00	7,10	500	4.000 3.000	4900	9800	8,0	0311205007 0311215007
M 6	0,5 - 3,0 3,0 - 5,5	16,00 18,50	8,90	9,80	9,10	500	3.000 3.000	7500	19100	12,0	0311206009 0311216009
M 8	0,5 - 3,0 3,0 - 5,5	18,00 20,50	10,90	11,80	11,10	250	1.500 1.000	9600	29800	38,0	0311208011 G311218011
M 10	0,5 - 3,5 3,5 - 6,0	22,00 24,00	12,90	14,00	13,10	150	900 500	12600	43300	70,0	0311201013 G311211013
M 12	1,0 - 4,0 4,0 - 8,0	25,00 28,00	16,00	17,50	16,10	100	600 300	17200	57800	98,0	0311201216 G311281216

NÝTOVACÍ MATICE ČÁSTEČNĚ ŠESTIHRANNÉ





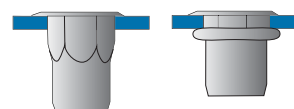
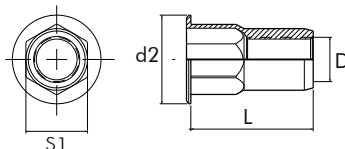

Nížká hlava – otevřená

OCEL



Pozinkovaná ocel A3K









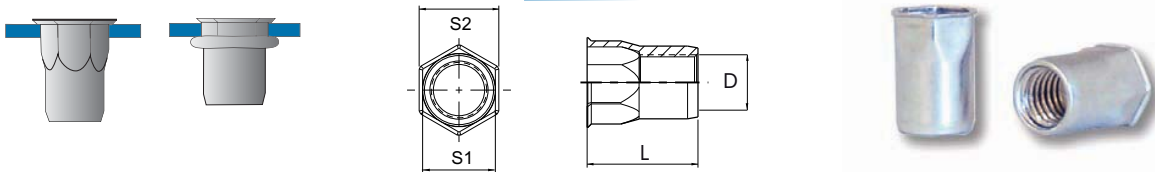

D	 E MIN. mm MÁX.	L	S1	d2	 mm	BALENÍ		 (N)	 (N)	 (Nm)	Kód zboží
						 vnitřní	 veknovní				
M 4	0,5 - 2,0	10,50	6,30	9,50	6,10	500	4.000	2800	7900	4,8	0331504006
M 5	0,5 - 2,5	11,80	7,10	9,90	7,20	500	4.000	3600	9800	9,4	0331505007
M 6	0,75 - 4,0	15,00	9,50	13,00	9,60	500	3.000	4700	19100	14,7	0331526009

OCEL







NÝTOVACÍ MATICE ČÁSTEČNĚ ŠESTIHRANNĚ Redukovaná zapuštěná hlava – otevřená

Pozinkovaná ocel A3K



D	 MIN. mm MÁX.	L Nominální mm	S1 Ø mm	S2 Ø mm	 mm	BALENÍ		 (N)	 (N)	 (Nm)	Kód zboží
						 vnitřní	 veknovní				
M 4	0,5 - 2,5	10,50	6,30	7,00	6,40	500	4.000	2900	7900	4,6	0331204006
M 5	0,5 - 3,0	12,00	7,10	8,00	7,20	500	4.000	3600	9800	6,2	0331205007
M 6	0,7 - 3,0	14,50	9,50	10,60	9,60	500	3.000	4700	19100	19,0	0331206009
M 8	0,8 - 3,0	16,50	10,50	11,50	10,60	250	1.500	5500	29800	34,0	0331208011

Pro palcové rozměry otvorů.

D	 MIN. mm MÁX.	L Nominální mm	S1 Ø mm	S2 Ø mm	 mm	BALENÍ		 (N)	 (N)	 (Nm)	Kód zboží
						 vnitřní	 veknovní				
M 4	0,5 - 2,5	10,50	5,90	7,00	6,10	500	4.000	2900	7900	4,6	0331204005
M 5	0,5 - 3,0	12,00	6,90	8,00	7,10	500	4.000	4300	9800	6,2	0331205006
M 6	0,7 - 3,0	14,50	8,90	10,00	9,10	500	3.000	5700	19100	19,0	0331206008
M 8	0,8 - 3,0	16,50	10,90	12,00	11,10	250	1.500	7000	29800	34,0	0331208010
M 10	1,0 - 3,5	20,00	12,90	14,50	13,10	150	900	7200	40700	72,0	0331201013





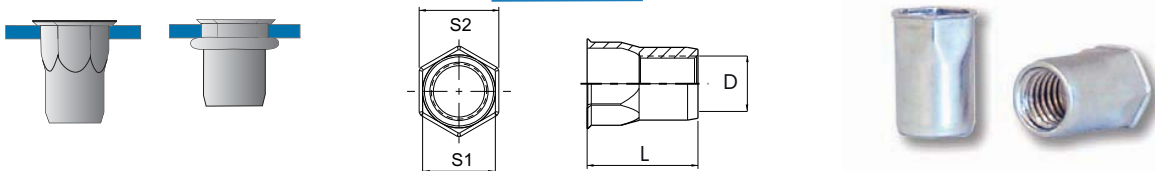

Pro metrické rozměry otvorů.

OCEL

NÝTOVACÍ MATICE ČÁSTEČNĚ ŠESTIHRANNĚ Redukovaná zapuštěná hlava – otevřená

Pozinkovaná ocel A3K



D	 MIN. mm MÁX.	L Nominální mm	S1 Ø mm	S2 Ø mm	 mm	BALENÍ		 (N)	 (N)	 (Nm)	Kód zboží
						 vnitřní	 veknovní				
M 6	0,7 - 3,0	15,00	8,90	10,00	9,10	500	3.000	5700	19100	19,0	0334206009
M 10	1,0 - 3,5	20,00	12,90	14,50	13,10	150	900	7200	40700	72,0	0334201013
	3,5 - 6,0	24,00									0334211013



NÝTOVACÍ MATICE HLADKÉ Velká hlava - Uzavřená

OCEL

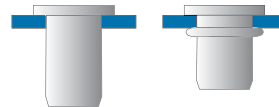
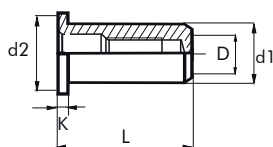

Pozinkovaná ocel A3K



D	E MIN. mm MÁX.	L Nominální mm	d1 Ø mm	d2 Ø mm	K mm	mm	BALENÍ		 (N)	 (N)	 (Nm)	Kód zboží
							vnitřní	veškovní				
M 5	0,5 - 2,5	18,00	6,90	10,00	1,00	7,10	500	3.000	5300	9800	7,0	0301405007
M 6	0,5 - 3,0	21,50	8,90	13,00	1,50	9,10	250	1.500	6300	20200	12,0	0301406009
M 8*	1,0 - 4,0	23,50	10,90	16,00	1,50	11,10	150	900	8300	29800	23,0	0301408011
M 10	1,0 - 4,0	31,00	12,90	19,00	2,00	13,10	50	300	13600	43300	35,1	0301401013

*Pozn: Tato matice má vroubkovanou hlavu.



NÝTOVACÍ MATICE ŠESTIHRANNÉ Velká hlava - Uzavřená

OCEL

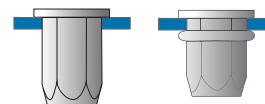
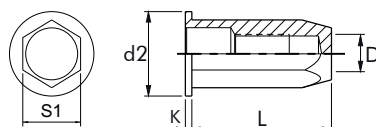

Pozinkovaná ocel A3K



D	E mm	L Nominální mm	S1 Ø mm	d2 Ø mm	K mm	mm	BALENÍ		 (N)	 (N)	 (Nm)	Kód zboží
							vnitřní	veškovní				
M 5	0,5 - 3,0	19,00	6,95	10,00	1,10	7,10	500	3.000	4900	9800	6,8	0311405007
M 6	0,5 - 3,0	21,50	8,95	13,00	1,50	9,10	250	1.500	7100	19100	22,0	0311406009
M 8	0,5 - 3,0	24,50	10,95	16,00	1,50	11,10	150	900	9600	29800	40,0	0311408011
M 10	1,0 - 3,5	31,00	12,95	19,00	2,00	13,10		500	12600	43000	70,0	G311401013





OCEL

NÝTOVACÍ MATICE VROUBKOVANÉ Redukovaná zapuštěná hlava - Uzavřená



Pozinkovaná ocel A3K



D	 E MIN. mm MÁX.	L	d1	d2	 mm	BALENÍ		 (N)	 (N)	 (Nm)	Kód zboží
						vnitřní	veškovní				
M 4	0,5 - 2,0	14,90	5,90	7,00	6,10	500	4.000	3000	7000	2,9	0375204006
M 5	0,5 - 3,0	18,00	6,90	8,00	7,10	500	3.000	5800	9800	6,0	0375205007
M 6	0,5 - 3,0	21,50	8,90	9,90	9,10	250	1.500	7100	19100	10,5	0375206009
M 8	0,5 - 3,0	22,50	10,90	12,00	11,10	250	1.500	8400	30000	15,5	0375208011



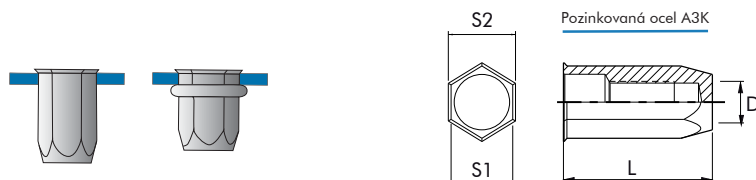

OCEL

NÝTOVACÍ MATICE ŠESTIHRANNÉ Redukovaná zapuštěná hlava - Uzavřená



Pozinkovaná ocel A3K



D	 E MIN. mm MÁX.	L	S1	S2	 mm	BALENÍ		 (N)	 (N)	 (Nm)	Kód zboží
						vnitřní	veškovní				
M 5	0,5 - 2,0	20,00	6,95	8,00	7,10	500	3.000	4900	9800	8,0	0311705007
M 6	0,5 - 3,0	22,00	8,95	10,0	9,10	250	1.500	7100	19100	12,0	0311706009





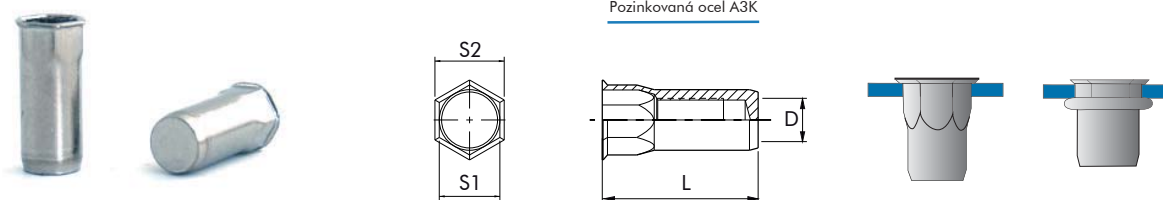

NÝTOVACÍ MATICE ČÁSTEČNĚ ŠESTIHRANNÉ

Redukovaná zapuštěná hlava - Uzavřená

OCEL



Pozinkovaná ocel A3K

D	 E MIN. MÁX. mm	L Nominální mm	S1 Ø mm	S2 Ø mm	 mm	BALENÍ		 (N)	 (N)	 (Nm)	Kód zboží
						 vnitřní	 veknovní				
M 4	0,5 - 2,5	16,50	5,90	7,00	6,10	500	4.000	2900	7900	4,6	0331704006
M 5	0,5 - 3,0	18,50	6,90	8,00	7,10	500	4.000	4300	9800	6,2	0331705007
M 6	0,5 - 3,0	21,50	8,90	10,00	9,10	250	1.500	5700	19100	19,0	0331706009
M 8	0,5 - 3,0	24,00	10,90	12,00	11,10	250	1.500	7000	29800	34,0	0331708011

NEREZOVÁ OCEL

NÝTOVACÍ MATICE HLADKÉ Velká hlava - Otevřená

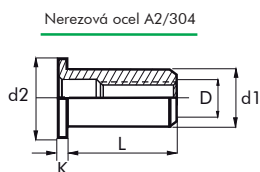

D	E MIN. mm MÁX.	L Nominalní mm	d1 Ø mm	d2 Ø mm	K mm	mm	BALENÍ		(N)	(N)	(Nm)	Kód zboží
							vnitřní	veškovní				
M 4	0,5 - 2,0	9,50	5,90	9,00	1,00	6,10	500	4.000	4900	10000	3,1	0303104006
M 5	0,5 - 3,0	12,00	6,90	10,00	1,00	7,10	500	4.000	6000	15800	6,9	0303105007
M 6	0,5 - 3,0	14,50	8,90	13,00	1,50	9,10	250	2.000	9000	21600	10,0	0303106009
M 8	0,5 - 3,0	16,50	10,90	15,00	1,50	11,10	250	1.500	12350	36300	19,3	0303108011

NEREZOVÁ OCEL

NÝTOVACÍ MATICE VROUBKOVANÉ Velká hlava - Otevřená

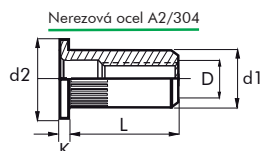
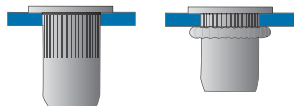

D	E MIN. mm MÁX.	L Nominalní mm	d1 Ø mm	d2 Ø mm	K mm	mm	BALENÍ		(N)	(N)	(Nm)	Kód zboží
							vnitřní	veškovní				
M 4	0,5 - 2,0	9,50	5,90	9,00	1,00	6,10	500	4.000	5600	9100	6,4	0373104006
M 5	0,5 - 3,0	12,00	6,90	10,00	1,00	7,10	500	4.000	6800	15800	8,4	0373105007
	3,0 - 4,5	13,50										
M 6	0,5 - 3,0	14,50	8,90	13,00	1,50	9,10	250	2.000	9000	23800	26,7	0373106009
M 8	0,5 - 3,0	16,50	10,90	16,00	1,50	11,10	250	1.500	10600	40600	62,5	0373108011
	3,0 - 5,5	18,50										
M 10	1,0 - 3,5	19,00	12,90	17,00	2,00	13,10	150	900	11300	>49000	111,7	0373101013

NÝTOVACÍ MATICE HLADKÉ





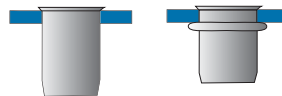
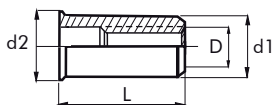

Redukovaná zapuštěná hlava - Otevřená

NEREZOVÁ OCEL



Nerezová ocel A2/304



D	 E MIN. mm MÁX.	L	d1	d2	 mm	BALENÍ		 (N)	 (N)	 (Nm)	Kód zboží
						 vnitřní	 veknovní				
M 4	0,5 - 2,0	11,00	5,90	7,00	6,10	500	4.000	4900	10000	2,2	0303204006
M 5	0,5 - 3,0	12,00	6,90	8,00	7,10	500	4.000	6000	15800	3,2	0303205007
M 6	0,5 - 3,0	14,50	8,90	10,00	9,10	500	3.000	9000	21600	5,8	0303206009
M 8	0,5 - 3,0	16,00	10,90	12,00	11,10	250	1.500	12350	36300	15,6	0303208011

NÝTOVACÍ MATICE VROUBKOVANÉ





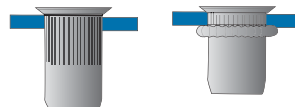
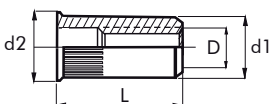

Redukovaná zapuštěná hlava - Otevřená

NEREZOVÁ OCEL



Nerezová ocel A2/304







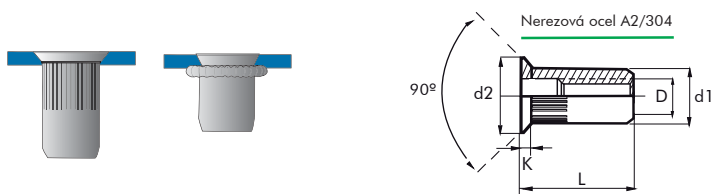

D	 E MIN. mm MÁX.	L	d1	d2	 mm	BALENÍ		 (N)	 (N)	 (Nm)	Kód zboží
						 vnitřní	 veknovní				
M 3	0,25 - 2,0	9,75	4,90	6,00	5,10	500	4.000	2700	3100	2,3	0373203005
M 4	0,5 - 2,0	10,50	5,90	7,00	6,10	500	4.000	4800	10300	5,5	0373204006
M 5	0,5 - 3,0	12,00	6,90	8,00	7,10	500	4.000	7300	14300	8,6	0373205007
M 6	0,5 - 3,0	14,50	8,90	10,00	9,10	500	3.000	9600	23700	14,7	0373206009
M 8	0,5 - 3,0	16,50	10,90	12,00	11,10	250	1.500	11300	38600	20,0	0373208011
M 10	1,0 - 3,5	19,00	12,90	14,20	13,10	150	900	13400	>49000	27,5	0373201013

NEREZOVÁ OCEL

NÝTOVACÍ MATICE VROUBKOVANÉ Zapuštěná hlava - Otevřená



D	 MIN. mm MAX.	L Nominální mm	d1 Ø mm	d2 Ø mm	K mm	 mm	BALENÍ		 (N)	 (N)	 (Nm)	Kód zboží
							 vnitřní	 veškovní				
M 4	1,5 - 3,0	12,00	5,90	9,00	1,50	6,10	500	4.000	4900	10000	4,1	0373304006
M 5	1,5 - 4,0	13,00	6,90	9,60	1,50	7,10	500	4.000	6000	12800	8,4	0373305007
M 6	1,5 - 4,0	16,00	8,90	12,00	1,50	9,10	250	2.000	9000	21600	27,9	0373306009
M 8	1,5 - 4,0	18,50	10,90	13,50	1,50	11,10	250	1.500	12350	36300	34,5	0373308011





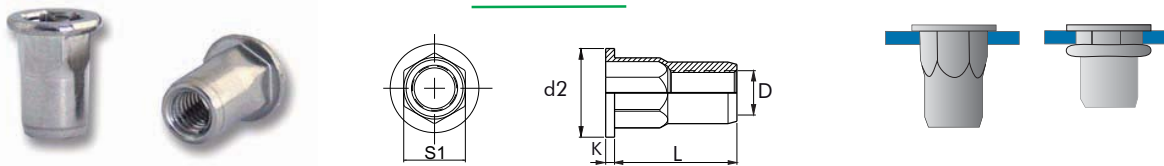

NÝTOVACÍ MATICE ČÁSTEČNĚ ŠESTIHRANNĚ

Velká hlava - Otevřená

NEREZOVÁ OCEL

Nerezová ocel A2/304



D	 E MIN. mm MÁX.	L Nominalní mm	S1 Ø mm	d2 Ø mm	K mm	 mm	BALENÍ		 (N)	 (N)	 (Nm)	Kód zboží
							 vnitřní	 veknovní				
M 5	0,5 - 3,0	12,00	6,90	10,00	1,50	7,10	500	4.000	3300	13200	9,1	0333105007
M 6	0,5 - 3,0	14,00	8,90	12,00	1,50	9,10	250	2.000	7700	21600	19,7	0333106009
M 8	0,5 - 3,0	16,00	10,90	15,00	1,50	11,10	250	1.500	11200	36300	26,5	0333108011





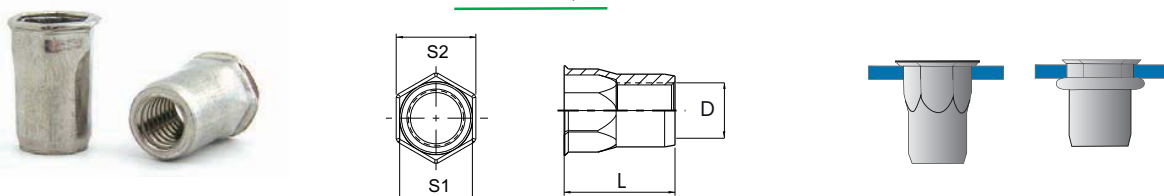

NÝTOVACÍ MATICE ČÁSTEČNĚ ŠESTIHRANNĚ

Redukovaná zapuštěná hlava - Otevřená

NEREZOVÁ OCEL

Nerezová ocel A2/304



D	 E MIN. mm MÁX.	L Nominalní mm	S1 Ø mm	S2 Ø mm	 mm	BALENÍ		 (N)	 (N)	 (Nm)	Kód zboží
						 vnitřní	 veknovní				
M 4	0,5 - 2,5	11,00	5,90	7,00	6,00	500	4.000	5600	10000	4,9	0333204006
M 5	0,5 - 3,0	12,00	6,90	8,00	7,00	500	4.000	7200	15800	8,8	0333205007
M 6	0,5 - 3,0	14,00	8,90	10,00	9,00	500	3.000	9600	18000	14,0	0333206009
M 8	0,5 - 3,0	16,00	10,90	12,00	11,00	250	1.500	11200	36300	26,5	0333208011
M 10	1,0 - 3,5	19,00	12,90	14,20	13,00	150	900	11400	47800	91,6	0333201013

NEREZOVÁ OCEL

NÝTOVACÍ MATICE HLADKÉ Velká hlava - Uzavřená

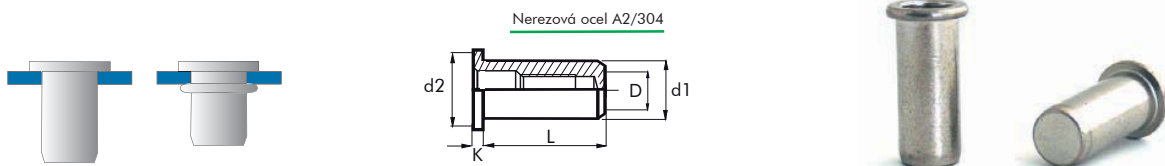

D	E MIN. mm MÁX.	L Nominální mm	d1 Ø mm	d2 Ø mm	K mm	BALENÍ		(N)	(N)	(Nm)	Kód zboží	
						vnitřní	veškovní					
M 4	0,5 - 2,5	16,00	5,90	9,00	1,00	6,10	500	4.000	4900	10000	2,2	0303404006
M 5	0,5 - 3,0	18,00	6,90	10,00	1,00	7,10	500	3.000	6000	15800	3,2	0303405007
M 6	0,5 - 3,0	21,00	8,90	12,00	1,50	9,10	250	1.500	9000	21600	10,3	0303406009
M 8	0,5 - 3,0	23,50	10,90	14,00	1,50	11,10	150	900	12350	36300	15,6	0303408011

NEREZOVÁ OCEL

NÝTOVACÍ MATICE ČÁSTEČNĚ ŠESTIHRANNÉ Velká hlava - Uzavřená

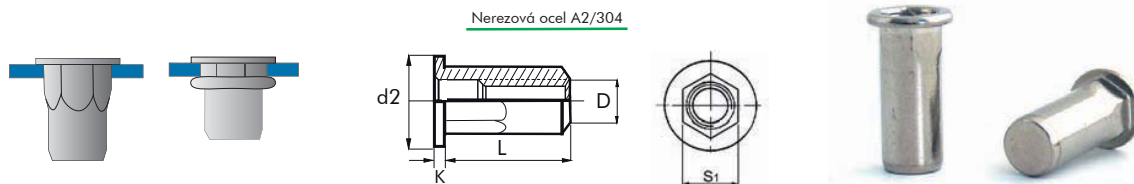







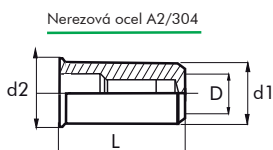

D	E MIN. mm MÁX.	L Nominální mm	S1 Ø mm	d2 Ø mm	K mm	BALENÍ		(N)	(N)	(Nm)	Kód zboží	
						vnitřní	veškovní					
M 5	0,5 - 2,0	18,00	6,90	10,00	1,00	7,10	500	3.000	7200	12000	8,8	0333405007
M 6	0,5 - 3,0	21,00	8,90	12,00	1,50	9,10	250	1.500	9000	21600	19,7	0333406009
M 8	0,5 - 3,0	23,50	10,90	14,00	1,50	11,10	200	1.200	11200	36300	26,5	0333408011

NÝTOVACÍ MATICE HLADKÉ

Redukovaná zapuštěná hlava - Uzavřená

NEREZOVÁ OCEL



D	 E mm	L Nominální mm	d1 Ø mm	d2 Ø mm	 mm	BALENÍ  vnitřní  veknovní	 (N)	 (N)	 (Nm)	Kód zboží
M 4	0,5 - 3,0	16,00	5,90	7,00	6,10	500 4.000	4900	10000	2,2	0303704006
M 5	0,5 - 3,0	18,00	6,90	8,00	7,10	500 3.000	6000	21600	3,2	0303705007
M 6	0,5 - 3,0	21,00	8,90	10,00	9,10	250 1.500	9000	24300	10,3	0303706009
M 8	0,5 - 3,0	23,50	10,90	12,00	11,10	250 1.500	12350	36300	15,6	0303708011

NÝTOVACÍ MATICE ČÁSTEČNĚ ŠESTIHRANNĚ





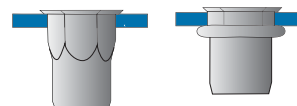
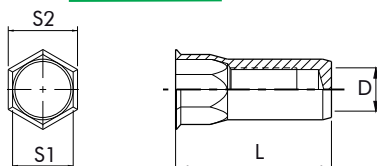

Redukovaná zapuštěná hlava - Uzavřená

NEREZOVÁ OCEL







Nerezová ocel A2/304

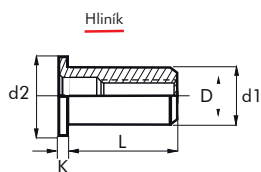







D	 E mm	L Nominální mm	S1 Ø mm	S2 Ø mm	 mm	BALENÍ  vnitřní  veknovní	 (N)	 (N)	 (Nm)	Kód zboží
M 4	0,5 - 2,5	16,00	5,90	7,00	6,10	500 4.000	5600	10000	4,9	0333704006
M 5	0,5 - 3,0	18,00	6,90	8,00	7,10	500 4.000	7200	12000	8,8	0333705007
M 6	0,5 - 3,0	21,00	8,90	10,00	9,10	250 1.500	9000	21600	15,5	0333706009
M 8	0,5 - 3,0	23,50	10,90	12,00	11,10	200 1.200	11200	36300	26,5	0333708011

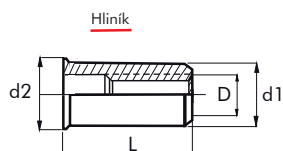
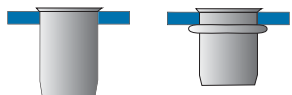

D	 E mm	L	d1	d2	K	 mm	BALENÍ		 (N)	 (N)	 (Nm)	Kód zboží
							vnitřní	veškovní				
M 4	0,5 - 2,0	9,50	5,90	9,00	1,00	6,10	500	4.000	3400	4300	2,0	0302104006
M 5	0,5 - 3,0	12,00	6,90	10,00	1,00	7,10	500	4.000	4400	8300	5,5	0302105007 0302115007
	3,0 - 5,5	15,00										
M 6	0,5 - 3,0	14,50	8,90	13,00	1,50	9,10	250	2.000	5000	10500	9,0	0302106009 0302116009
	3,0 - 5,5	16,50										
M 8	0,5 - 3,0	16,50	10,90	16,00	1,50	11,10	250	1.500	6000	15400	16,9	0302108011 0302118011
	3,0 - 5,5	18,50										

Pozn: Na dotaz umíme nabídnout výrobu uzavřených hliníkových nýtovacích matic. Pro informace ohledně minimálního množství a dodacího termínu nás prosím kontaktujte.









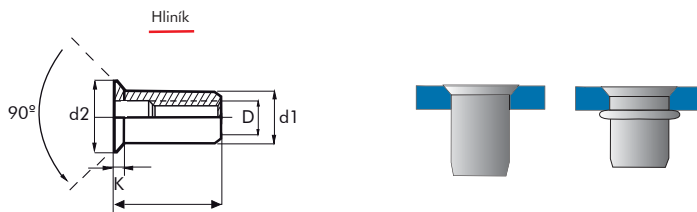

D	 E mm	L	d1	d2	 mm	BALENÍ		 (N)	 (N)	 (Nm)	Kód zboží
						vnitřní	veškovní				
M 5	0,5 - 3,0	12,00	6,90	8,00	7,10	500	4.000	4400	8300	5,5	0302205007
M 6	0,5 - 3,0	14,50	8,90	10,00	9,10	500	3.000	5000	10500	9,0	0302206009
M 8	0,5 - 3,0	16,00	10,90	12,00	11,10	250	1.500	6000	15400	16,9	0302208011

NÝTOVACÍ MATICE HLADKÉ

Zapuštěná hlava - Otevřená

HLINÍK







D	 E MIN. mm MÁX.	L Nominalní mm	d1 Ø mm	d2 Ø mm	K mm	 mm	BALENÍ		 (N)	 (N)	 (Nm)	Kód zboží
							 vnitřní	 veškovní				
M 4	1,5 - 3,5	11,50	5,90	8,50	1,50	6,10	500	4.000	3400	4300	2,0	0302304006
M 5	1,5 - 4,0	13,00	6,90	9,50	1,50	7,10	500	4.000	4400	8300	5,5	0302305007
M 6	1,5 - 4,0	16,00	8,90	11,50	1,50	9,10	250	2.000	5000	10500	9,0	0302306009
M 8	1,5 - 4,5	18,50	10,90	13,50	1,50	11,10	250	1.500	6000	15400	16,9	0302308011

NÝTOVACÍ ŠROUBY

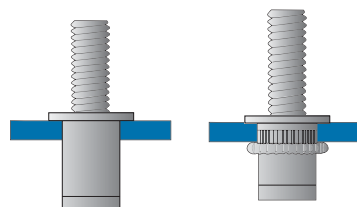
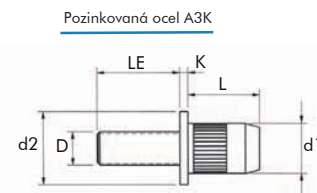
Velká hlava

OCEL



D	 E MIN. mm MÁX.	L Nominalní mm	d1 Ø mm	d2 Ø mm	K mm	LE mm	 mm	BALENÍ		Kód zboží
								 vnitřní	 veškovní	
M 5	0,5 - 3,0	11,00	6,95	10,00	1,00	15,00	7,10	500	3.000	0370005015
M 6	0,5 - 3,0	13,00	8,95	13,00	1,00	15,00	9,10	250	1.500	0370006015
	0,5 - 3,0	13,00				20,00		200	1.200	0370006020
	0,5 - 3,0	13,00				25,00		150	900	0370006025
M 8	0,5 - 3,0	16,00	10,95	16,00	1,50	20,00	11,10	150	900	0370008020
	0,5 - 3,0	16,00				25,00		100	600	0370008025

Balení: blistry a minikrabičky

BRALO nabízí rozličné druhy balení.

Naše standardní balení pro běžnou distribuci nabízí řadu výhod, zejména odolnost, přehlednost a snadné použití. Blistry a minikrabičky nabízejí řešení pro prodej v malých množstvích, jsou lehké, pevné, snadno přenosné. Neváhejte nás kontaktovat pro více informací.



HLINÍK/OCEL

SADA NÝTŮ V PLASTOVÉM KUFŘÍKU Plochá hlava



NÝTY	OBSAH KUFŘÍKU KIT	Kód zboží
4x 8 - 4x12	50 ks/rozměr	F1010004048
4,8x12 -4,8x16	40 ks/rozměr	

POZNÁMKA: Minimální množství: 1 balení obsahující 7 kufříků

PRODEJNÍ STOJANY

Prodejní stojany pro přehlednou nabídku minibalení na prodejních

- Jednoduchá montáž a demontáž
- Způsob prezentace, který přivola pozornost více zákazníků
- Možnost vystavení různých produktů
- Snadno doplnitelný



Ruční nýtovací kleště pro trhací nýty



BRALO RUČNÍ NÝTOVACÍ KLEŠTĚ Které kleště vybrat?

NÝT Ø m/m	MATERIAL	BM-45	BM-75	BM-85	BM-67	BM-92	BM-160	BM-164
2,4	Hliník, nerez	✓	✓	✓				
3,0	Hliník, ocel, nerez, měď	✓	✓	✓	✓	✓	✓	
3,2	Hliník, ocel, nerez, měď	✓	✓	✓	✓	✓	✓	
4,0	Hliník, ocel, nerez, měď	✓	✓	✓	✓	✓	✓	
4,8	Hliník	✓	✓	✓	✓	✓	✓	✓
4,8	Ocel, nerez, měď	✓	✓	✓	✓	*	✓	✓
4,8	Pevnostní STRUCTURAL						*	
5,0	Hliník				✓	✓		✓
5,0	Ocel, nerez				*	*	✓	✓
6,0	Hliník				*	*	✓	✓
6,0	Ocel, nerez							✓
6,4	Hliník				*			✓
6,4	Ocel, nerez							✓
6,5	Pevnostní STRUCTURAL							*
5,2 - 6,4	Rozpěrný S-Trebol						*	*
7,7	Rozpěrný S-Trebol							*

*Vyžaduje použití dodatečného příslušenství (není součástí standardního balení).

CHARAKTERISTIKA ručního nýtovacího náradí pro trhací nýty

ŠTÍHLÝ DESIGN pro lepší přístup do hůře dostupných míst

Hlavní tělo z **HLINÍKOVÉ SLITINY**

PŘEVODOVÝ SYSTÉM redukuje požadavek na sílu a snižující rázy

Odlehčené **OCELOVÉ PÁKY**

PŘÍSLUŠENSTVÍ umístěné **UVNITŘ**, či na **KLEŠTÍCH**

ERGONOMICKÉ RUKOJETI pro pohodlné použití

Pro **VENKOVNÍ I VNITŘNÍ POUŽITÍ**.



RUČNÍ NÝTOVACÍ KLEŠTĚ na nýty

BM-45

TECHNICKÉ ÚDAJE

HMOTNOST: 0,530 kg
DĚLKA: 250mm
ZDVIH: 5mm
POUŽITÍ: do 5mm (Al)

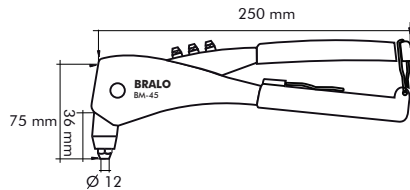

POLOŽKA	Kód zboží
BM 45 v blistru	92BM00450
BM 45 v plastovém boxu s nýty	02BM00453 <small>BM-45 + (Al/Si 3,2x8 4,0x10 4,8x12 a 50 ks)</small>

NÝTY Ø m/m	MATERIÁLU			
	Hliník	Ocel	Nerez	Měď
2,4	✓		✓	
3,0 - 3,2	✓	✓	✓	✓
4,0	✓	✓	✓	✓
4,8 - 5,0	✓			



BM-75

TECHNICKÉ ÚDAJE

HMOTNOST: 600 grs.
DĚLKA: 265 mm.
ZDVIH: 6 mm.
POUŽITÍ: do 5mm (Al)

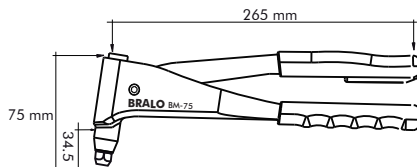

POLOŽKA	Kód zboží
BM 75	02BM00750
BM 75 v blistru	92BM00750
BM 75 v plastovém boxu s nýty	02BM0075PB <small>BM-75 + (Al/Si 3,2x8 4,0x10 4,8x12 a 50 ks)</small>
BM 75 KOVOVÝ KUFR	02BM00752 <small>BM-75 + (Al/Si 3,2x8 4,0x10 4,8x12 a 50 ks)</small>

NÝTY Ø m/m	MATERIÁLU			
	Hliník	Ocel	Nerez	Měď
2,4	✓		✓	
3,0 - 3,2	✓	✓	✓	✓
4,0	✓	✓	✓	✓
4,8 - 5,0	✓			



BM-85

TECHNICKÉ ÚDAJE

HMOTNOST: 670 grs.
DĚLKA: 265 mm.
ZDVIH: 6 mm.
POUŽITÍ: do 5mm (Al)

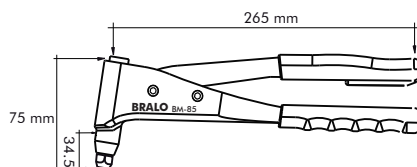

POLOŽKA	Kód zboží
BM 85	02BM00850
BM 85 v plastovém boxu s nýty	02BM0085PB <small>BM-85 + (Al/Si 3,2x8 4,0x10 4,8x12 a 50 ks)</small>
BM 85 KOVOVÝ KUFR	02BM00852 <small>BM-85 + (Al/Si 3,2x8 4,0x10 4,8x12 a 50 ks)</small>

NÝTY Ø m/m	MATERIÁLU			
	Hliník	Ocel	Nerez	Měď
2,4	✓		✓	
3,0 - 3,2	✓	✓	✓	✓
4,0	✓	✓	✓	✓
4,8 - 5,0	✓			



BM-67

RUČNÍ NÝTOVACÍ KLEŠTĚ na nýty



POLOŽKA	Kód zboží
BM 67	02BM00670

NÝTY Ø m/m	MATERIÁLU			
	Hliník	Ocel	Nerez	Měď
3,0	✓	✓	✓	✓
3,2	✓	✓	✓	✓
4,0	✓	✓	✓	✓
4,8	✓	✓	✓	✓
5,0	✓	*	*	
6,0	*	*	*	
6,4	*	*	*	

*Pro dlouhodobé použití doporučujeme klešť BM-164.

POPIS

- Extra dlouhé tělo pro hůře přístupná místa.
- Typ nářadí umožňující zanýťování nýtu jednou rukou.
- Tělo a rukojeť nářadí vyrobeno z hliníkové slitiny o vysoké hustotě.
- Pohodlná rukojeť pro lepší nýťování.
- Harmoniková část vyrobená z kvalitní oceli.
- Násadky prakticky umístěny v rukojeti kleští.

TECHNICKÉ ÚDAJE

HMOTNOST: 1.920 grs.
DÉLKA SEVŘENÉ: 300 mm.
DÉLKA ROZEVŘENÉ: 755 mm.
ZDVIH: 8 mm.
POUŽITÍ: do 6,4 mm (Al)

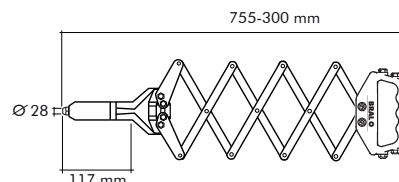

BM-92



POLOŽKA	Kód zboží
BM 92	02BM00920

NÝTY Ø m/m	MATERIÁLU			
	Hliník	Ocel	Nerez	Měď
3,0	✓	✓	✓	✓
3,2	✓	✓	✓	✓
4,0	✓	✓	✓	✓
4,8	✓	*	*	*
5,0	✓	*	*	
6,0	*	*	*	

*Nutno použít speciální násadku - není součástí balení.

POPIS

- Vyrobeno z oceli nejvyšší kvality.
- Tvar hlavy pro nýťování v obtížně přístupných místech.
- Pohodlná a ergonomická rukojeť.
- Možno nýťovat pohybem pouze jedné páky kleští v omezených prostorech.
- Násadky prakticky umístěny na kleštích.

TECHNICKÉ ÚDAJE

HMOTNOST: 1.590 grs.
DÉLKA SEVŘENÉ: 440 mm.
ZDVIH: 10 mm.
POUŽITÍ: do 6 mm (Al)

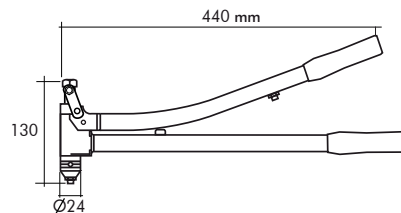

POPIS

- Kvalitní kleště s kratší pákou
- Tělo kleští z vysoce kvalitní hliníkové slitiny.
- Páky a spoje z vysoce kvalitní oceli pro vyšší odolnost
- Pohodlné a ergonomické rukojeti.
- Sběrač trnů pro pořádek a bezpečnost na pracovišti
- Masivní, bezpečné a odolné kleště
- Násadky prakticky umístěny ve sběrači trnů.

TECHNICKÉ ÚDAJE

HMOTNOST: 1360 grs.
DÉLKA SEVŘENÉ: 390 mm.
ZDVIH: 10,5 mm.
POUŽITÍ: do 6,0 mm hliník a 6,4 S-Trebol.

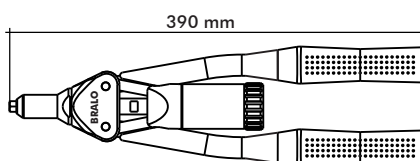

POLOŽKA	Kód zboží
BM 160	02BM01600
BM 160 v plastovém boxu s nýty	02BM01602

NÝTY Ø m/m	MATERIÁLU			
	Hliník	Ocel	Nerez	Měď
3,0 - 3,2	✓	✓	✓	✓
4,0	✓	✓	✓	✓
4,8	✓	✓	✓	✓
4,8 Structural	*	*	*	
5,0	✓	✓	✓	✓
6,0	✓	✓	✓	✓
5,2 S- Trebol	*			
6,4 S-Trebol	**			

*Nutno použít speciální násadku - není součástí balení.

**Nutno použít násadku a čelisti - nejsou součástí balení.



POPIS

- Kvalitní kleště s kratší pákou
- Tělo kleští z vysoce kvalitní hliníkové slitiny.
- Páky a spoje z vysoce kvalitní oceli pro vyšší odolnost
- Pohodlné a ergonomické rukojeti.
- Sběrač trnů pro pořádek a bezpečnost na pracovišti
- Masivní, bezpečné a odolné kleště
- Násadky prakticky umístěny ve sběrači trnů.

TECHNICKÉ ÚDAJE

HMOTNOST: 1420 grs.
DÉLKA SEVŘENÉ: 405 mm.
ZDVIH: 10,5 mm.
POUŽITÍ: do 6,0 mm hliník a 6,4 S-Trebol.

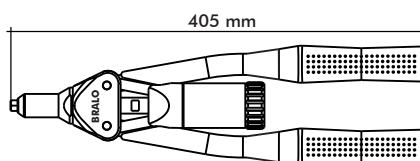

POLOŽKA	Kód zboží
BM 164	02BM01640
BM 164 v plastovém boxu s nýty	02BM01642

NÝTY Ø m/m	MATERIÁLU			
	Hliník	Ocel	Nerez	Měď
4,8	✓	✓	✓	✓
5,0	✓	✓	✓	✓
6,0	✓	✓	✓	✓
6,4	✓	✓	✓	✓
6,5 Structural	**	**	**	
5,2 S-Trebol	*			
6,4 S-Trebol	*			
7,7 S-Trebol	**			

*Nutno použít speciální násadku - není součástí balení.

**Nutno použít násadku a čelisti - nejsou součástí balení.



Pneumatické nářadí pro zásobníkové nýty SPEED RIVETS

BRALO RR-10 je olejo-pneumatické nářadí pro aplikaci nýtů SPEED RIVETS BSR, BSV. Jedná se o lehké ergonomické a efektivní nářadí. Je vhodným pro použití v montážních linkách s možností použití pro všechny průměry od 3,2 do 4,8 mm.

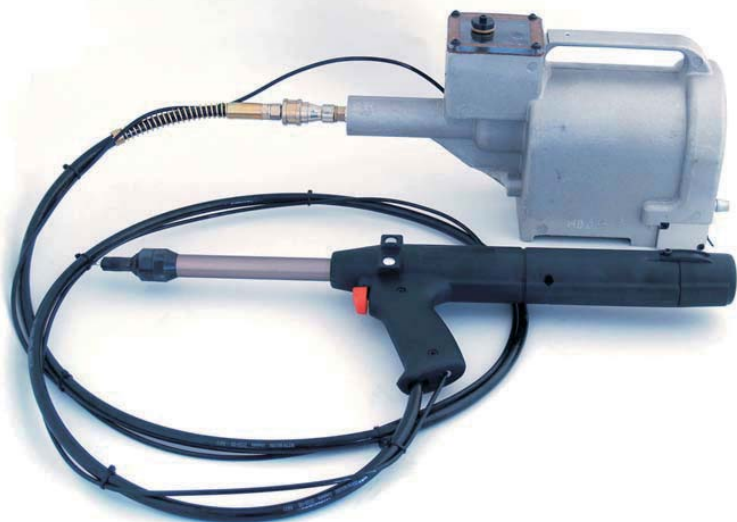

TECHNICKÉ ÚDAJE

HMOTNOST: 2.800 grs.
 DÉLKA SEVŘENÉ: 540 mm.
 Pracovní tlak: 5,5-6,5 bar
 Spotřeba vzduchu: 0,8 l / nýt
 ZDVIH: 21 mm.
 Rozsah: do 4,8 mm

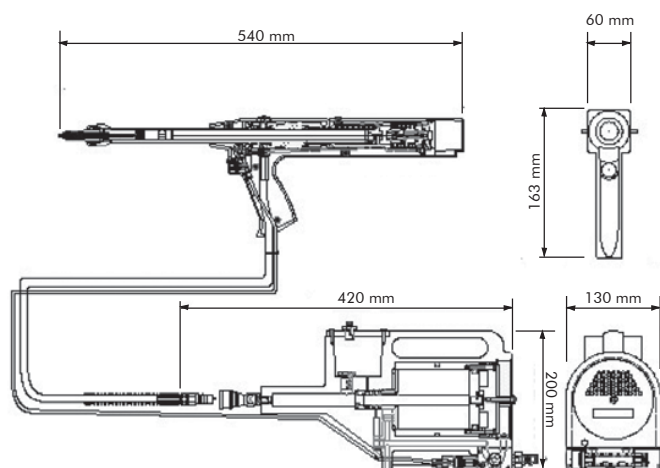

POLOŽKA	Kód zboží
RR-10 Ø 3,2	02RR00103
RR-10 Ø 4,0	02RR00104
RR-10 Ø 4,8	02RR00105

NÝTY Ø m/m	MATERIÁLU			
	Hliník	Ocel	Nerez	Měď
3,2	✓	✓	✓	✓
4,0	✓	✓	✓	✓
4,8	✓	✓	✓	✓

PNEUMATICKO-HYDRAULICKÉ NÁŘADÍ PRO TRHACÍ NÝTY



BRALO PNEUMATICKÉ NÝTOVACÍ NÁŘADÍ Které pneumtické nářadí vybrat?

NÝT Ø m/m	MATERIAL	BM-516	BM-525	BM-718	BM-917	BM-928
2,4	Hliník, nerez	✓	✓	*		
3,0 - 3,2	Hliník, ocel, nerez	✓	✓	✓		
3,0 - 3,2	nerez	✓	✓	✓		
4,0	Hliník, ocel, nerez, měď	✓	✓	✓		
4,8	Hliník	✓	✓	✓	*	**
4,8	Ocel, nerez, měď	✓		✓	✓	**
5,0	Hliník		✓	✓	*	**
5,0	Ocel, nerez			✓	✓	**
6,0	Hliník			✓	✓	**
6,0	Ocel, nerez				✓	**
6,4	Hliník, ocel, nerez				✓	**
3,2 Hardgrip	nerez	✓	✓	✓		
3,2 - 4,0 Hardgrip	Ocel			✓		
4,8 Hardgrip	Ocel			✓	✓	**
6,0 Hardgrip	Ocel, nerez				✓	**
6,4 Hardlock	Hliník, ocel, nerez				***	*
4,8 Structural	Hliník, ocel, nerez			*	*	**
6,5 Structural	Hliník				**	✓
5,2 S-Trebol	Hliník		*	*	*	**
6,4 S-Trebol	Hliník			*	*	**
7,7 S-Trebol	Hliník				**	*

* Vyžaduje použití speciální násadky (není součástí standardního balení).

** Vyžaduje použití speciální násadky a čelistí (nejsou součástí standardního balení).

*** Vyžaduje použití speciálních čelistí (nejsou součástí standardního balení).

CHARAKTERISTIKA pneumtického nýtovacího nářadí pro trhací nýty

Hlavní tělo vyrobeno z vysoce odolné
HLINÍKOVÉ SLITINY

Vybavené OKEM
pro **ZAVĚŠENÍ**

SBĚRAČ TRNŮ
poskytující čistotu a bezpečnost

Využití jedné stlačeného vzduchu
pro celý **NÝTOVACÍ CYKLUS**

ERGONOMICKÁ rukojeť

UZÁVĚR přívodu vzduchu

Odolná
GUMOVÁ ZÁKLADNA

VYVÁŽENÉ tělo



www.bralo.cz

REMACHES - BLIND RIVETS - RIVETS - BLINDNIETE - RIVETTI - REBITES
TUERCAS REMACHABLES - INSERT NUTS - ECROUS À SERTIR - BLINDNIETMUTTERN - INSERTI - PORCAS DE REBITAR

BM-516



Ref: 02BM05160

NÝTY Ø m/m	MATERIÁLU			
	Hliník	Ocel	Nerez	Měď
2,4	✓		✓	
3,0	✓			
3,2	✓	✓	✓	✓
3,2 - 4,0 Hardgrip		✓	✓	
4,0	✓	✓	✓	✓
4,8	✓			
5,0	✓			

Pneumatiké kleště na nýty

TECHNICKÉ ÚDAJE

HMOTNOST: 1.690 grs.
ZDVIH: 16 mm.
POUŽITÍ: do 5,0 mm (Al).

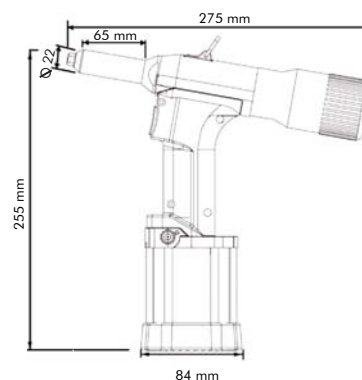

BM-525



Ref: 02BM05250

NÝTY Ø m/m	MATERIÁLU			
	Hliník	Ocel	Nerez	Měď
2,4	✓		✓	
3,0 3,2	✓	✓	✓	✓
3,2 - 4,0 Hardgrip		✓	✓	
4,0	✓	✓	✓	✓
4,8 - 5,0	✓			

TECHNICKÉ ÚDAJE

HMOTNOST: 1.760 grs.
ZDVIH: 25 mm.
POUŽITÍ: do 4,8-5,0 mm (Al)
Speciální násadka na 5,2mm
S-Trebol – není součástí balení.

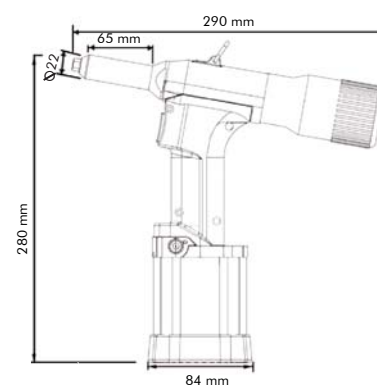

BM-718



Ref: 02BM07180

NÝTY Ø m/m	MATERIÁLU			
	Hliník	Ocel	Nerez	Měď
3,0 - 3,2	✓	✓	✓	✓
3,2 - 4,0 Hardgrip		✓	✓	
4,0	✓	✓	✓	✓
4,8	✓	✓	✓	
5,0	✓	✓	✓	
4,8 Hardgrip		✓	✓	
6,0	✓			

TECHNICKÉ ÚDAJE

HMOTNOST: 1.770 grs.
ZDVIH: 18 mm.
POUŽITÍ: do 6,0mm (Al) a do 4,8mm
u nýtu Hard Grip
Speciální násadky pro 5,2 a 6,4 S-Trebol nýty
a pro 4,8 Pevnostní nýty – nejsou součástí balení

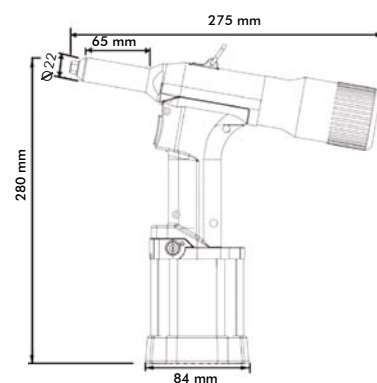

www.bralo.cz

REMACHES - BLIND RIVETS - RIVETS - BLINDNIETE - RIVETTI - REBITES
TUERCAS REMACHABLES - INSERT NUTS - ECROUS À SERTIR - BLINDNIETMUTTERN - INSERTI - PORCAS DE REBITAR

PNEUMATICKÉ NÝTOVACÍ KLEŠTĚ na nýty

BM-917

TECHNICKÉ ÚDAJE

HMOTNOST: 2.420 grs.
 ZDVIH: 17 mm.
 POUŽITÍ: od 4,8 - 6,4mm
 Speciální čelisti a násadky pro 6,4
 Structural, Hardlock a 7,7 mm S-Trebol – nejsou
 součástí balení.

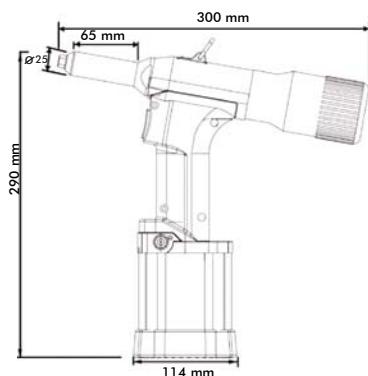

Ref: 02BM09170

NÝTY Ø m/m	MATERIÁLU			
	Hliník	Ocel	Ocel	Měď
4,8	✓	✓	✓	✓
5,0	✓	✓	✓	
6,0 - 6,4	✓	✓	✓	
4,8 Hardgrip		✓	✓	
6,0 Hardgrip		✓	✓	



BM-928

TECHNICKÉ ÚDAJE

HMOTNOST: 2.570 grs.
 ZDVIH: 28 mm.
 POUŽITÍ: 6,5mm pevnostní nýty Structural.
 Násadky a čelisti pro nýty 4,8-6,4 mm a speciální násadka
 pro nýt 7,7 mm S-Trebol – nejsou součástí balení.

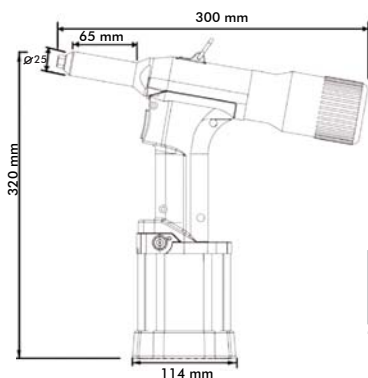

Ref: 02BM09280

NÝTY Ø m/m	MATERIÁLU			
	Hliník	Ocel	Ocel	Měď
6,5 Structural	✓	✓	✓	



Akumulátorové nýtovací nářadí pro trhací nýty



Akumulátor 1,4 Ah Li-Ion 14,4 V.
Kód zboží: 05BET100018



Akumulátor 2,8 Ah Li-ion 14,4 V.
Kód zboží: 05BET100019



Nabíječka akumulátorů 14,4 V
Kód zboží: 05BET000020



CHARAKTERISTIKA akumulátorového nýtovacího nářadí pro trhací nýty

INDIKÁTOR stavu akumulátoru

Vybavené **OKEM** pro **ZAVĚŠENÍ**

Jednoduše vyprázdnitelný **SBĚRAČ TRNŮ**

ERGONOMICKÁ a POHODLNÁ rukojeť

CITLIVÁ spoušť

SKVĚLE VYVÁŽENÝ design

VÝKONNÝ Li-Ion akumulátor



Akumulátorové nýtovací nářadí pro trhací nýty

BET-1

TECHNICKÉ ÚDAJE

HMOTNOST: 1.690 grs.
DÉLKA: 284 mm.
ZDVIH: 20 mm.
POUŽITÍ: do 5,00mm
SÍLA TAHU: 10.000N.
HMOTNOST BATERIE 1,4 AH.: 0,34KG
NAPĚTÍ: 14.4V

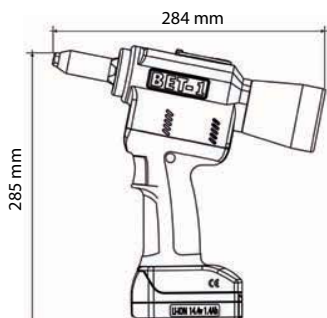

NÝTY Ø m/m	MATERIÁLU			
	Hliník	Ocel	Nerez	Měď
2,4	✓	✓	✓	✓
3,0 - 3,2	✓	✓	✓	✓
4,0	✓	✓	✓	✓
4,8 - 5,0	✓	✓	✓	✓

POLOŽKA	Kód zboží
BET-1 1 Akumulátor 1,4 Ah	02BET1010
BET-1 2 Akumulátor 1,4 Ah	02BET1020
BET-1 UK 1 Akumulátor 1,4 Ah	02BET1030
BET-1 UK 2 Akumulátor 1,4 Ah	02BET1040
BET-1 MX 1 Akumulátor 1,4 Ah	02BET1050
BET-1 MX 2 Akumulátor 1,4 Ah	02BET1060



BET-2

TECHNICKÉ ÚDAJE

HMOTNOST: 1,690kg
DÉLKA: 284 mm.
ZDVIH: 27 mm.
POUŽITÍ: do 6,4mm.
SÍLA TAHU: 18.000 N.
HMOTNOST BATERIE 2,8 AH.: 0,58 KG.
NAPĚTÍ: 14.4V

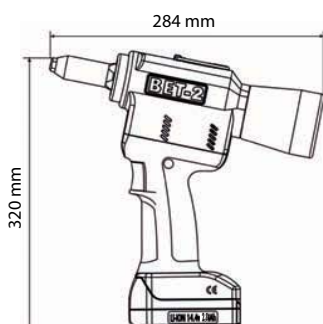

NÝTY Ø m/m	MATERIÁLU		
	Hliník	Ocel	Nerez
4,8 - 5,0	✓	✓	✓
6,0 - 6,4	✓	✓	✓
4,8 - 6,0 Hardgrip	✓	✓	✓
6,4 Hardlock	✓	✓	✓
4,8 Structural	✓	✓	✓
6,5 Structural	✓	✓	✓
5,2 - 6,4 S-Trebol	*		
7,7 S-Trebol	**		

*Nutno použít speciální násadku - není součástí balení.

**Nutno použít speciální násadku a další díly - nejsou součástí balení.

POLOŽKA	Kód zboží
BET-2 1 Akumulátor 2,8Ah.	02BET2010
BET-2 UK 1 Akumulátor 2,8Ah.	02BET2030
BET-2 MX 1 Akumulátor 2,8Ah.	02BET2050



Ruční nýtovací kleště na NÝTOVACÍ MATICE



T-105

Ruční nýtovací kleště na NÝTOVACÍ MATICE

POPIS

- Úzký design pro přístup do obtížných míst.
- Tělo je vyrobeno z hliníkové slitiny.
- Odlehčené ocelové páky.
- Ergonomické rukojeti pro lepší nýtování.
- Klíč na trny umístěn na kleštích.

TECHNICKÉ ÚDAJE

HMOTNOST: 670 grs.
 DÉLKA: 265 mm.
 ŠÍŘKA: 115 mm.
 ZDVIH: 7,0 mm.
 POUŽITÍ: M-3 to M-6

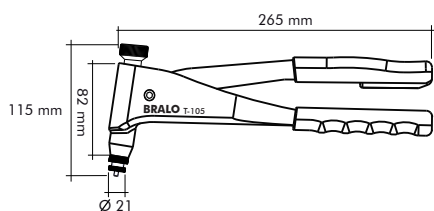

POLOŽKA	Kód zboží
T 105	02TR01050
T 105 PLASTIC BOX	02TR0105PB T-105 + příslušenství M4, M5 a M6 ocelové nýtovací matice
T 105 METAL BOX	02TR01052 T-105 + příslušenství M4, M5 a M6 ocelové nýtovací matice

NÝTY Ø	MATERIÁLU			
	Hliník	Ocel	Nerez	Mosaz
M-3	✓	✓	✓	✓
M-4	✓	✓	✓	✓
M-5	✓	✓	✓	✓
M-6	✓	✓	✓	✓



POPIS

- Tělo kleští z vysoce kvalitní hliníkové slitiny.
- Jednoduché použití bez potřeby vynaložení větší síly.
- Ergonomické rukojeti pro snadnější nýtování.
- Snadné nastavení a zafixování potřebné síly nastavovací maticí.
- Ruční natočení a vytočení nýt. matice pomocí centrální otočné rukojeti.

TECHNICKÉ ÚDAJE

HMOTNOST: 1.470 grs.
DÉLKA: 390 mm.
ZDVIH: 7.0 mm.
POUŽITÍ: M-3 až M-8.

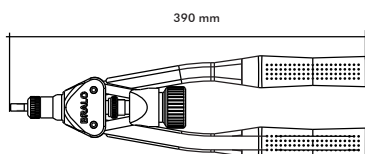

POLOŽKA	Kód zboží
TR 308 v plastovém kufříku	02TR03080

NÝTY Ø m/m	MATERIÁLU			
	Hliník	Ocel	Nerez	Mosaz
M-3	✓	✓	✓	✓
M-4	✓	✓	✓	✓
M-5	✓	✓	✓	✓
M-6	✓	✓	✓	✓
M-8	✓	✓	✓	✓

Pozn: Tyto kleště mohou sloužit pro aplikaci nýtovacích šroubů. Je potřeba použít speciální díly nabízené jako volitelné příslušenství – nejsou součástí balení.



POPIS

- Jednoduché použití bez potřeby vynaložení větší síly.
- Tělo kleští z vysoce kvalitní hliníkové slitiny.
- Páky a další díly vyrobeny z oceli nejvyšší kvality.
- Pohodlné a ergonomické rukojeti.
- Snadné nastavení a zafixování potřebné síly nastavovací maticí.
- Ruční natočení a vytočení nýt. matice pomocí centrální otočné rukojeti.

TECHNICKÉ ÚDAJE

HMOTNOST: 1.510 grs.
DÉLKA: 390 mm.
ZDVIH: 7.0 mm.
POUŽITÍ: M-6 až M-12.

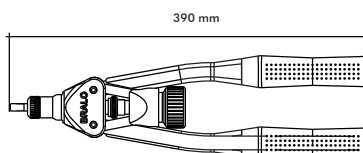

POLOŽKA	Kód zboží
TR 312 v plastovém kufříku	02TR03120

NÝTY Ø m/m	MATERIÁLU			
	Hliník	Ocel	Nerez	Mosaz
M-6	✓	✓	✓	✓
M-8	✓	✓	✓	✓
M-10	✓	✓	✓	✓
M-12	✓	✓	✓	✓



Pneumatické nýtovací nářadí pro nýtovací matice

Pneumaticko-hydraulické nýtovací kleště pro rychlou a snadnou aplikaci nýtovacích matic. TR-2001 je silné ergonomické nářadí s výkonným aplikačním systémem vyvinuté pro zvládnutí nejnáročnějších aplikací. Velmi vhodné pro použití na výrobních linkách.

Vybavené **OKEM** pro **ZAVEŠENÍ**

JEDNA ovládací **SPOUŠŤ**

Hlavní tělo vyrobeno z vysoce odolné **HLINIKOVÉ SLITINY**

VYVÁŽENÉ tělo

ERGONOMICKÁ a POHODLNÁ rukojeť

Odolné vnitřní **OLEOPNEUMATICKÉ ÚSTROJÍ** z oceli vysoké kvality

Odolná **GUMOVÁ ZÁKLADNA**



TR-2001

PNEUMATICKÉ NÝTOVACÍ NÁŘADÍ pro nýtovací matice

TECHNICKÉ ÚDAJE

HMOTNOST: 2.790 grs.
DÉLKA: 285 mm.
VÝŠKA: 300 mm.
ŠÍŘKA: 115 mm.
ZDVIH: 21 mm.
POUŽITÍ: Do M-12

POLOŽKA	Kód zboží
TR 2001	02TR20010

NÝTY Ø m/m	MATERIÁL			
	Hliník	Ocel	Nerez	Mosaz
M-4	✓	✓	✓	✓
M-5	✓	✓	✓	✓
M-6	✓	✓	✓	✓
M-8	✓	✓	✓	✓
M-10	✓	✓	✓	✓
M-12	✓	✓		

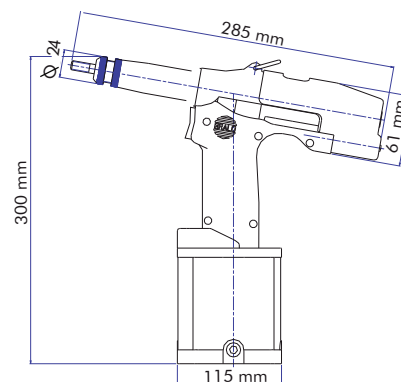

Kopírování tohoto materiálu bez našeho souhlasu je zakázáno. Možnost změn vyhrazena. Pro aktuální informace nás neváhejte kontaktovat.

www.bralo.cz

REMACHES - BLIND RIVETS - RIVETS - BLINDNIETE - RIVETTI - REBITES
TUERCAS REMACHABLES - INSERT NUTS - ECROUS À SERTIR - BLINDNIETMUTTERN - INSERTI - PORCAS DE REBITAR

